

**AAMA/WDMA/CSA 101/IS.2/A440-08
TEST REPORT**

Rendered to:

EAGLE WINDOW & DOOR, INC.

**PRODUCT TYPE: Series 93 Clad Auxiliary
SERIES/MODEL: Aluminum Clad Fixed Wood Window**

Title	Summary of Results
Primary Product Designator	CW-PG75 1524 x 2438 (60 x 96)-FW
Design Pressure	3600 Pa (75.0 psf)
Air Infiltration	<0.05 L/s/m ² (<0.01 cfm/ft ²)
Canadian Air Infiltration/Exfiltration Level	Fixed
Water Penetration Resistance Test Pressure	580 Pa (12.0 psf)
Uniform Load Structural Test Pressure	±5400 Pa (112.5 psf)
Forced Entry Resistance	Grade 40

Test Completion Date: 03/15/07

Reference must be made to Report No. 71131.01-201-44, dated 02/19/09 for complete test specimen description and data.

AAMA/WDMA/CSA 101/I.S.2/A440-08 TEST REPORT

Rendered to:

EAGLE WINDOW & DOOR, INC.
2045 Kerper Boulevard, P.O. Box 1072
Dubuque Iowa 52004-1072

Report No.: 71131.01-201-44
Test Date: 03/15/07
Original Report Date: 04/03/07
Revised Report Date: 02/19/09
Record Retention Date: 03/15/11

Project Summary: Architectural Testing, Inc. was contracted by Eagle Window & Door to perform testing on a Series/Model Series 93 Clad Auxiliary, Aluminum Clad Fixed Wood window. The sample tested successfully met the performance requirements for a CW-PG75 1524 x 2438 (60 x 96)-FW rating. Test specimen description and results are reported herein.

Test Specification: The test specimen was evaluated in accordance with AAMA/WDMA/CSA 101/I.S.2/A440-08, *NAFS - North American Fenestration Standard/Specification for Windows, Doors, and Skylights*.

Test Specimen Description:

Series/Model: Series 93 Clad Auxiliary

Product Type: Aluminum Clad Fixed Wood window

Overall Size: 1524 mm (60") wide by 2438 mm (96") high

Daylight Opening Size: 1422 mm (56") wide by 2337 mm (92") high

Overall Area: 3.7 m² (40.0 ft²)

Finish: Interior wood was natural, exterior cladding was painted.

Test Specimen Description: (Continued)

Frame Construction: The wood frame was comprised of laminated veneer lumber with corners square cut, butted, sealed with silicone and secured with two 11 mm (7/16") by 38 mm (1-1/2") staples and two corrugated fasteners per corner. Extruded aluminum cladding was slip-fit over the wood frame members with the corners miter cut, sealed with silicone and secured with a nylon corner key, two #6 by 11 mm (7/16") screws and one #10 by 64 mm (2-1/2") screw per corner.

Glazing Details: The window utilized a nominal 25 mm (1") thick insulating glass unit fabricated from two nominal 5.7 mm sheets of annealed glass separated by a desiccant filled metal spacer system. The glass was set from the interior against butyl rubber mastic and silicone. Wood glazing stops with single sided adhesive foam tape were utilized on the interior and secured with 32 mm (1-1/4") brads 25 mm (1") from each corner, spaced 152 mm to 203 mm (6" to 8") on center.

Installation: The window was installed within a wood test buck. The window was anchored to the buck with #10 by 76 mm (3") wood screws spaced 152 mm (6") from each corner and midspan on the jambs and 152 mm (6") from ends on the head and sill and through the railing fin with 51 mm (2") roofing nails spaced 89 mm (3-1/2") from each corner and 152 mm (6") on center. Silicone sealant was used to seal the window to the test buck.

Test Results: The temperature during testing was 21°C (70°F). The results are tabulated as follows:

<u>Paragraph</u>	<u>Title of Test - Test Method</u>	<u>Results</u>	<u>Allowed</u>
5.3.2.1	Air Leakage Resistance per ASTM E 283		
	75 Pa (1.6 psf)	<0.05 L/s/m ² (<0.01 cfm/ft ²)	1.5 L/s/m ² (0.3 cfm/ft ² max.)
	300 Pa (6.2 psf)	<0.05 L/s/m ² (<0.01 cfm/ft ²)	-- --

Note #1: *The tested specimen meets (or exceeds) the performance levels specified in AAMA/WDMA/CSA 101/I.S.2/A440-08 for air leakage resistance.*

5.3.2.2	Canadian Infiltration/Exfiltration Level: Fixed		
	75 Pa (1.6 psf) Infiltration	<0.05 L/s/m ² (<0.01 cfm/ft ²)	0.20 L/s/m ² max. (0.04 cfm/ft ²) max.
	75 Pa (1.6 psf) Exfiltration	<0.05 L/s/m ² (<0.01 cfm/ft ²)	0.20 L/s/m ² max. (0.04 cfm/ft ²) max.

Test Results: (Continued)

<u>Paragraph</u>	<u>Title of Test - Test Method</u>	<u>Results</u>	<u>Allowed</u>
5.3.3.2	Water Penetration Resistance per ASTM E 547		See Note #2
5.3.4.2	Uniform Load Deflection per ASTM E 330		See Note #2
5.3.4.3	Uniform Load Structural per ASTM E 330		See Note #2

Note #2: *The client opted to start at a pressure higher than the minimum required. Those results are listed under "Optional Performance".*

5.3.5	Forced Entry Resistance per ASTM F 588		
	Type: D	Grade: 40	
	Lock Hardware Manipulation Test	No entry	No entry
	Sash/Panel Manipulation Test	No entry	No entry

Optional Performance

4.3.2.1	Water Penetration Resistance per ASTM E 547 and E 331 580 Pa (12.0 psf)	No leakage	No leakage
4.3.2.1	Uniform Load Deflection per ASTM E 330 (Deflections were taken on the frame) (Loads were held for 60 seconds)		
	3600 Pa (75.0 psf) (positive)	<0.3 mm (<0.01")	0.8 mm (0.03")
	3600 Pa (75.0 psf) (negative)	0.3 mm (0.01")	0.8 mm (0.03")

Note #3: *The deflections reported are not limited by AAMA/WDMA/CSA 101/I.S.2/A440-08 for this product designation. The deflection data is recorded in this report for special code compliance and information only.*

4.3.2.1	Uniform Load Structural per ASTM E 330 (Permanent sets were taken on the frame) (Loads were held for 10 seconds)		
	5400 Pa (112.5 psf) (positive)	<0.3 mm (<0.01")	0.5 mm (0.02") max.
	5400 Pa (112.5 psf) (negative)	0.5 mm (0.02")	0.5 mm (0.02") max.

Tape and film were used to seal against air leakage during structural testing. In our opinion, the tape and film did not influence the results of the test.

Drawing Reference: The test specimen drawings have been reviewed by Architectural Testing and are representative of the test specimen reported herein.

List of Official Observers:

<u>Name</u>	<u>Company</u>
Edward J. Popp	Architectural Testing, Inc.
Eric J. Schoenthaler	Architectural Testing, Inc.

Detailed drawings, data sheets, representative samples of test specimens, a copy of this report, or other pertinent project documentation will be retained by Architectural Testing, Inc. for a period of four years from the original test date. At the end of this retention period, such materials shall be discarded without notice and the service life of this report will expire.

Results obtained are tested values and were secured by using the designated test methods. No conclusions of any kind regarding the adequacy or inadequacy of the glass in the test specimen can be made. This report does not constitute certification of this product nor an opinion or endorsement by this laboratory. It is the exclusive property of the client so named herein and relates only to the specimen tested. This report may not be reproduced, except in full, without the written approval of Architectural Testing, Inc.

For ARCHITECTURAL TESTING, INC.

Eric J. Schoenthaler
Project Manager

Daniel A. Johnson
Director - Regional Operations

EJS/mb;jb

Attachments (pages): This report is complete only when all attachments listed are included.

- Appendix A: Alteration Addendum (1)
- Appendix B: WDMA Submittal Forms (2)
- Appendix C: Drawings (8)

Revision Log

<u>Rev. #</u>	<u>Date</u>	<u>Page(s)</u>	<u>Revision(s)</u>
0	04/03/07	N/A	Original report issue. Reports and drawings forwarded to AMS for Hallmark Certification
1	12/02/08	All	Test report results conducted prior to 2008 standard being published, report is as compared to 2008 standard. Reports and drawings forwarded to AMS for Hallmark Certification
2	02/19/09	Cover and page 1	Changed classification. Report and drawings forwarded to AMS for Hallmark Certification.

Appendix A
Alteration Addendum

Note: No alterations were required,

Appendix B
WDMA Submittal Forms



WDMA HALLMARK CERTIFICATION PROGRAM REPORT SUBMISSION FORM

THIS FORM IS TO BE COMPLETED BY THE MANUFACTURER AND SUBMITTED TO AMS PRIOR TO OR ALONG WITH SUBMISSION OF EACH NEW OR REVISED TEST REPORT FOR CERTIFICATION TO THE HALLMARK PROGRAM. ANY QUESTIONS PLEASE CONTACT AMS AT 315-646-2234 OR staff@amscert.com.

Manufacturer: Eagle Window and Door, Inc.

Contact: Todd Bergstrom

Plant Location(s):
(list all plants where product is made)
2045 Kerper Blvd., Dubuque, IA 52004-1072

Phone: 563-556-2270

Test Report #: 71131.01-201-44-R1

Email: tbergstrom@eaglewindow.com

Product Relationship:

Extension of currently certified product? yes no n/a Recertification New (check one)

If yes, what CCL # ? 099-H-678.00

Difference from Certified Product: Report re-written to A440.08 standard.

Is this a Gateway Test ? yes no n/a

Does this report require a Gateway Report # ? yes no n/a Report #: _____

Impact Report:

If this is not an impact report check here:

AWS Report # _____

Test Plan # ? yes no n/a _____

Installation Instructions submitted ? yes no n/a

Certification to Florida:

If this will not be submitted to Florida check here:

AMS to Input to Database yes no n/a

Manufacturer to input yes no n/a



WDMA HALLMARK CERTIFICATION PROGRAM REPORT SUBMISSION FORM

Product Name: Series 93 Clad Auxiliary
(as to be listed on CCL)

Product Type: Fixed Window

Additional Manufacturer ID #: _____

n/a

<u>Hallmark CCL</u>	<u>Standard</u>	<u>Rating</u>
<input type="checkbox"/>	ANSI/AAMA/NWWDA 101/I.S. 2 97	_____
<input type="checkbox"/>	101/I.S.2/NAFS-02	_____
<input type="checkbox"/>	AAMA/WDMA/CSA/101/I.S.2/A440-05	_____
<input checked="" type="checkbox"/>	AAMA/WDMA/CSA/101/I.S.2/A440-08	CW-PG75 1524 x 2438 (60 x 96)-FW
<input type="checkbox"/>	ASTM E 1996 99 / E1886-97	_____
<input type="checkbox"/>	ASTM E 1996 01 / E1886-97	_____
<input type="checkbox"/>	ASTM E 1996 02 / E1886-02	_____
<input type="checkbox"/>	ASTM E 1996 03 / E1886-02	_____
<input type="checkbox"/>	ASTM E 1996 04 / E1886-04	_____
<input type="checkbox"/>	ASTM E 1996 05 / E1886-05	_____
<input type="checkbox"/>	ASTM E330 02	_____
<input type="checkbox"/>	ANSI A250.13-03	_____
<input type="checkbox"/>	TAS 201-94	_____
<input type="checkbox"/>	TAS 202-94	_____
<input type="checkbox"/>	TAS 203-94	_____
<input type="checkbox"/>	Other:	_____

Appendix C

Drawings



Architectural Testing

Test sample complies with these details.
Deviations are noted.

Report# 71131
Date 3/15/07 Tech PC

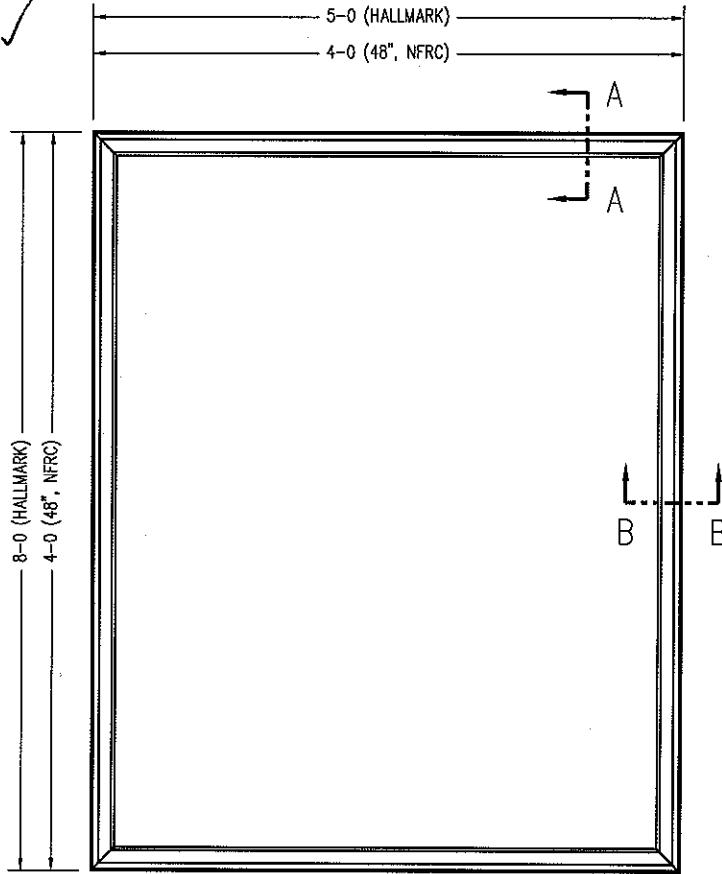
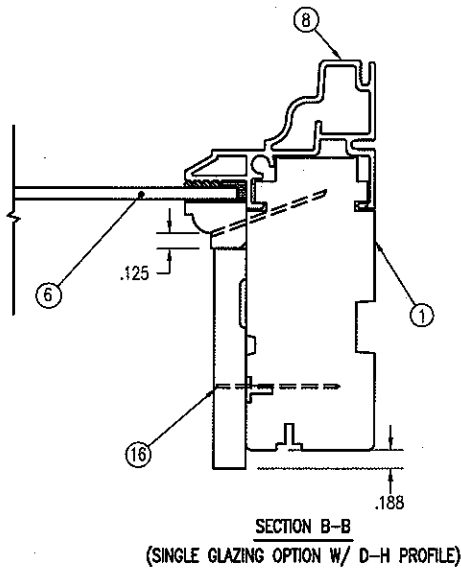
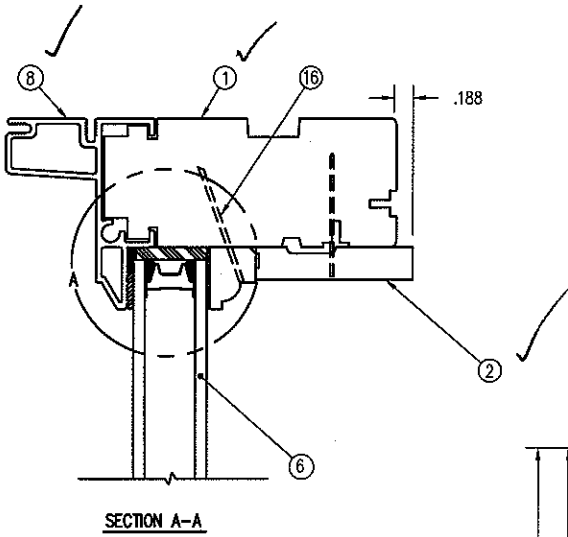

EXTERIOR VIEW

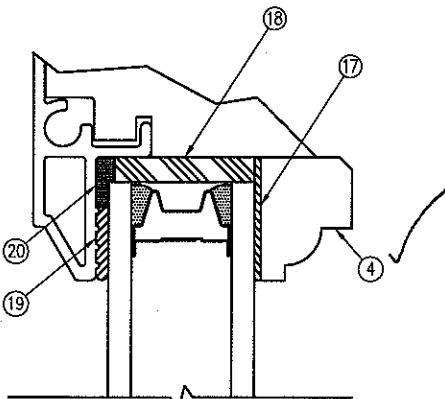

THIS DRAWING AND ITS CONTENTS ARE THE PROPERTY OF EAGLE WINDOW & DOOR. NO USE OR REPRODUCTION OF THE CONTENTS OF THIS DOCUMENT IS PERMITTED WITHOUT THE EXPRESS WRITTEN PERMISSION OF EAGLE WINDOW & DOOR.			
TITLE: CLAD AUXILIARY UNIT ASSEMBLY			
FINISH:			
MATERIAL:			
DFT:	TWN	SCALE:	1=2
DCN:	0710	DRWG:	0385
DATE:	8/12/02	C	01 OF 05

NO	DESCRIPTION	DFT	DOC	DATE



Architectural Testing

Test sample complies with these details.
Deviations are noted.

Report# 71131
Date 3/15/07 Tech PC

.392 DIA. x 82" CSK
(4 PLCS)

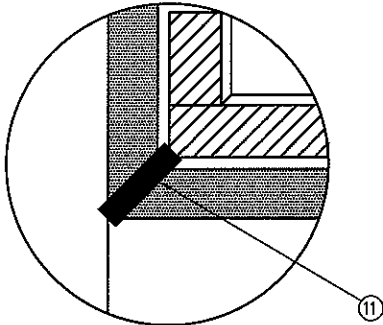

DETAIL A

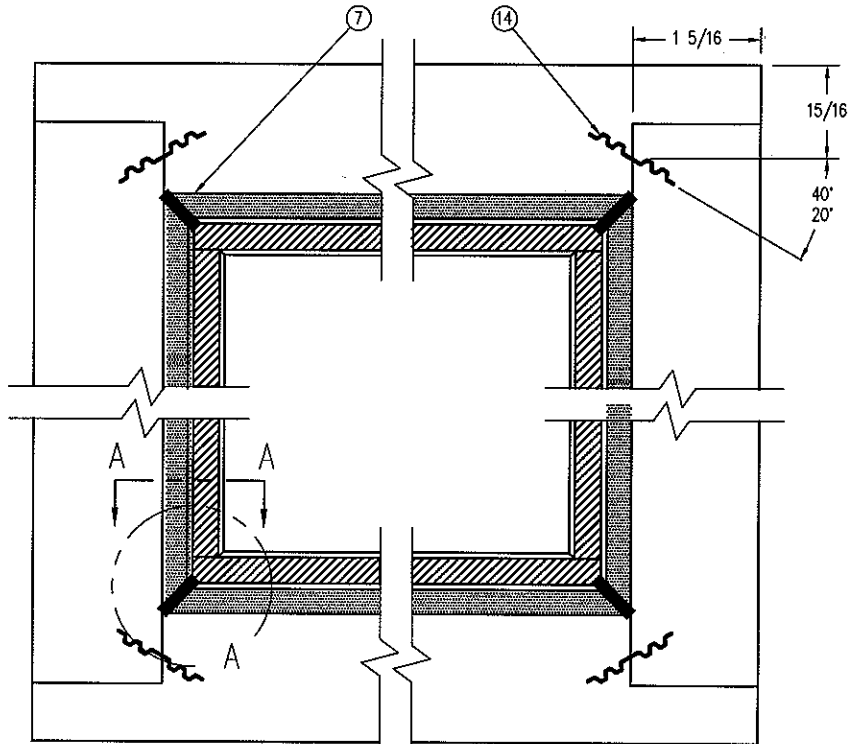
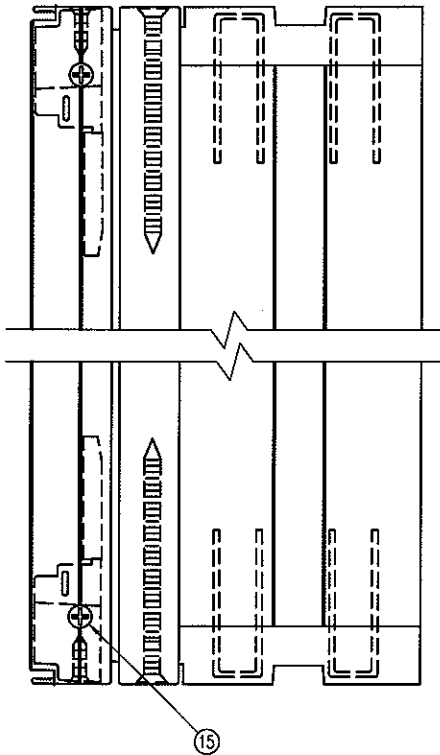
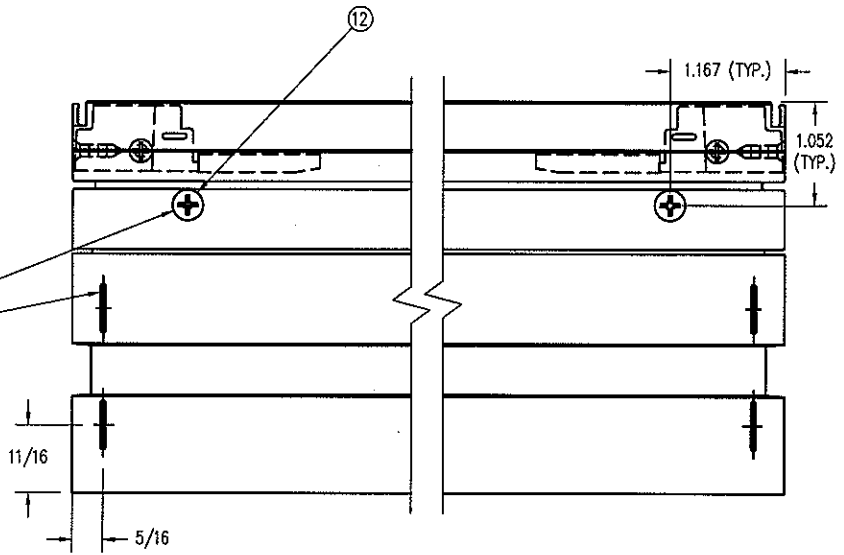

INTERIOR VIEW SHOWN WITHOUT GLASS OR STOPS

THIS DRAWING AND ITS CONTENTS ARE THE PROPERTY OF EAGLE WINDOW & DOOR. NO USE OR REPRODUCTION OF THE CONTENTS OF THIS DOCUMENT IS PERMITTED WITHOUT THE EXPRESS WRITTEN PERMISSION OF EAGLE WINDOW & DOOR.

TITLE:	CLAD AUXILIARY UNIT ASSEMBLY		
FINISH:			
MATL:			
DFT:	TWN	SCALE:	1=2
DCN:	0710	DRWG:	0385
DATE:	8/12/02	C	03

NO	DESCRIPTION	DFT	DOC	DATE



Architectural Testing

Test sample complies with these details.
Deviations are noted.

Report# 71131
Date 3/15/07 Tech PC

NO.	DWG. NO.	DESCRIPTION	QUANTITY	MATERIAL	SUPPLIER
1	✓ 220C	FRAME MEMBERS	4	WOOD (LVL)	EAGLE WINDOW AND DOOR
2	✓ 203B	SECONDARY STOP	4	WOOD	EAGLE WINDOW AND DOOR
3					
4	✓ 220J	COLONIAL GLAZING STOP	4	WOOD	EAGLE WINDOW AND DOOR
5					
6	A019	INSULATED GLASS	1	GLASS	CARDINAL IG
	A32Y	MONOLITHIC	1	GLASS	CARDINAL IG
	A024	MDL GLASS	1	GLASS	CARDINAL IG
7	A030	SILICONE SEALANT	AS REQUIRED	SILICONE	DOW CORNING
8	A554	AUXILIARY FRAME CLADDING	4	ALUMINUM	BONNELL
	A555	DH AUXILIARY FRAME CLADDING	4	ALUMINUM	BONNELL
9	A08W	CORNER KEY	4	ABS COMPOUND	LAKE COUNTRY SALES
10	A100	90° NYLON FRAME CORNER	4	NYLON	LAKE COUNTRY SALES
11	A24Y	SEAM SEALER SEALANT	AS REQUIRED	POLYETHELENE	SCHNEE-MOREHEAD
12	A046	#10 X 2 1/2 SS SMS	4	STEEL	ABILITY FASTENERS
13	A15Y	7/16" X 1 1/2" STAPLE	8	STEEL	PACKAGING CORP.
14	A02Y	1/2" X 1" CORRUGATED FASTNER	4	STEEL	PACKAGING CORP.
15	A11K	#8 x 7/16" PHIL. #6 FH. WS.	8	STEEL	ABILITY FASTENERS
16	A40F	1 1/4" HARDENED STEEL BRAD (18GA)	AS REQUIRED	STEEL	
17	A67M	ADHESIVE FOAM TAPE	AS REQUIRED	POLYETHELENE	ADHESIVE RESEARCH
18	A00E	GLASS SETTING, NEOPRENE	AS REQUIRED	NEOPRENE RUBBER	CLIM-A-TECH
19	A01A	SEALANT BUTYL TAPE	AS REQUIRED	BUTYL RUBBER	PTI INC.
20	A08K	GLAZING SHIM	AS REQUIRED	NEOPRENE RUBBER	CLIM-A-TECH
21	H-40	5/8" BETWEEN GLASS MUNTIN	AS REQUIRED	ALUMINUM	ALLMETAL
22	P/PD	1" CONTOUR MUNTIN	AS REQUIRED	ALUMINUM	ALLMETAL
23	220H	1 1/2" INTERIOR COLONIAL MDL BAR	AS REQUIRED	WOOD	EAGLE
24	H-40	SPACER CHANNEL	AS REQUIRED	ALUMINUM	ALLMETAL
25	A507	1 1/2" EXTERIOR MDL BAR	AS REQUIRED	ALUMINUM	BONNELL
26	A67X	1 1/2" MDL ADHESIVE TAPE (EXT. TAPE)	AS REQUIRED	POLYETHELENE	ADHESIVE RESEARCH
27	A67L	1 1/2" MDL ADHESIVE TAPE (INT. TAPE)	AS REQUIRED	POLYETHELENE	ADHESIVE RESEARCH
28	220H	1 1/8" INTERIOR COLONIAL MDL BAR	AS REQUIRED	WOOD	EAGLE
29	H-40	SPACER CHANNEL	AS REQUIRED	ALUMINUM	ALLMETAL
30	A507	1 1/8" EXTERIOR MDL BAR	AS REQUIRED	ALUMINUM	BONNELL
31	A67W	1 1/8" MDL ADHESIVE TAPE (EXT. TAPE)	AS REQUIRED	POLYETHELENE	ADHESIVE RESEARCH
32	A67R	1 1/8" MDL ADHESIVE TAPE (INT. TAPE)	AS REQUIRED	POLYETHELENE	ADHESIVE RESEARCH
33	220H	7/8" INTERIOR COLONIAL MDL BAR	AS REQUIRED	WOOD	EAGLE
34	H-40	SPACER CHANNEL	AS REQUIRED	ALUMINUM	ALLMETAL
35	A507	7/8" EXTERIOR MDL BAR	AS REQUIRED	ALUMINUM	BONNELL
36	A67T	7/8" MDL ADHESIVE TAPE (EXT. TAPE)	AS REQUIRED	POLYETHELENE	ADHESIVE RESEARCH
37	A67N	7/8" MDL ADHESIVE TAPE (INT. TAPE)	AS REQUIRED	POLYETHELENE	ADHESIVE RESEARCH
38	N/A	ADHESIVE FOAM TAPE	AS REQUIRED	POLYETHELENE	CARDINAL

THIS DRAWING AND ITS CONTENTS ARE THE PROPERTY OF EAGLE WINDOW & DOOR. NO USE OR REPRODUCTION OF THE CONTENTS OF THIS DOCUMENT IS PERMITTED WITHOUT THE EXPRESS WRITTEN PERMISSION OF EAGLE WINDOW & DOOR.

TITLE: CLAD AUXILIARY UNIT ASSEMBLY

FINISH:

MATL:

DFT: TWN SCALE: 1=2
DCN: 0710 DRWG: 0385
DATE: 8/12/02 C 05

NO	DESCRIPTION	DFT	DOC	DATE

1. (52) 2" ROOFING NAILS THROUGH NAIL FIN INTO BUCK SPACES 3 1/2" FROM EACH END AND 6" ON CENTER THEREAFTER.

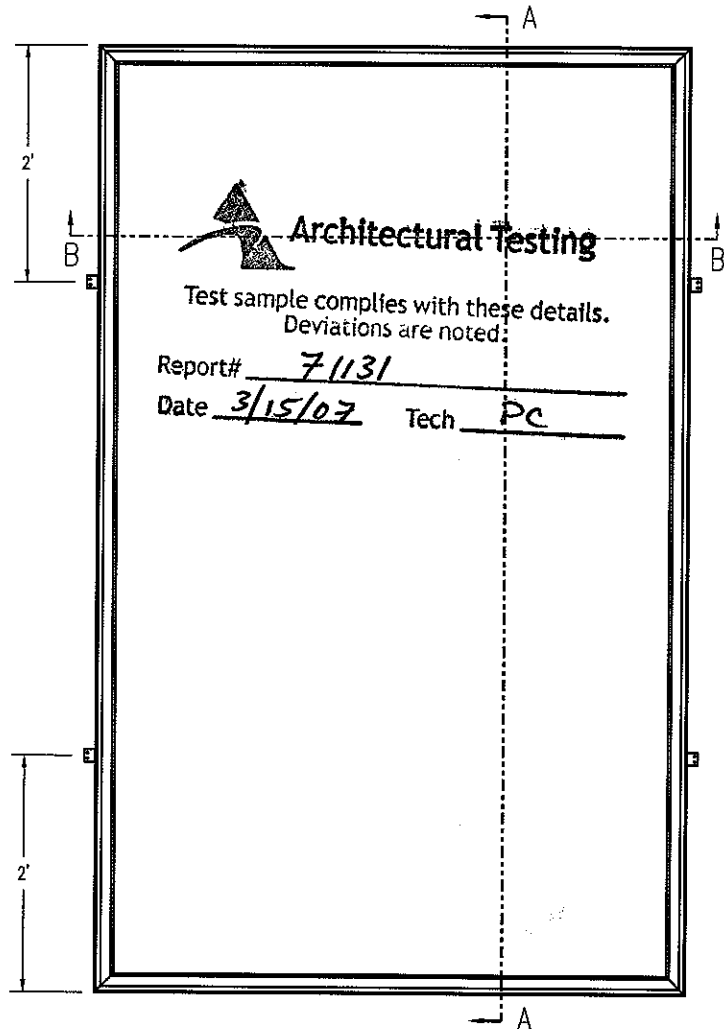
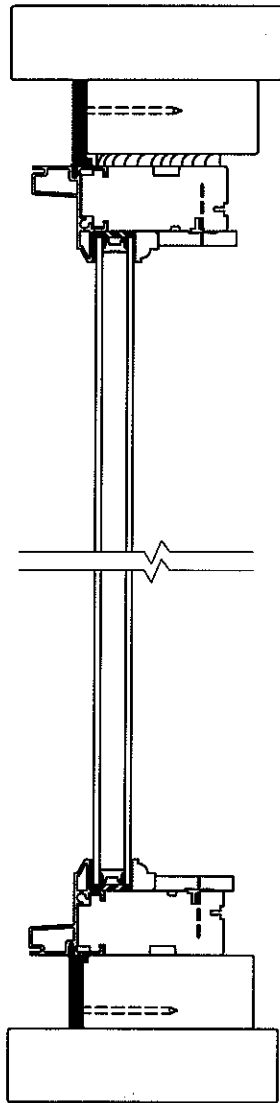
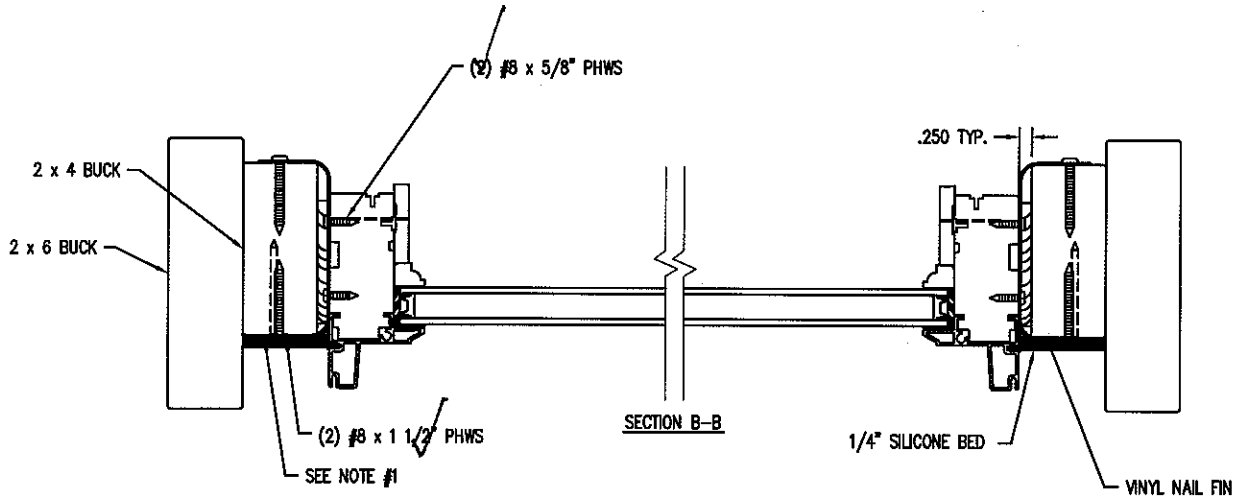

5080 CLAD AUXILIARY
EXTERIOR VIEW

THIS DRAWING AND ITS CONTENTS ARE THE PROPERTY OF EAGLE WINDOW & DOOR. NO USE OR REPRODUCTION OF THE CONTENTS OF THIS DOCUMENT IS PERMITTED WITHOUT THE EXPRESS WRITTEN PERMISSION OF EAGLE WINDOW & DOOR.			
TITLE: 5080 CLAD AUXILIARY INSTALLATION DETAIL			
FINISH:			
MATL:			
DFT:	TWN	SCALE:	1=4
DCN:	0710	DRWG:	0459
DATE:	11/18/04	C	01 OF 01

NO	DESCRIPTION	DFT	DOC	DATE
----	-------------	-----	-----	------

- NOTE: 1. UNLESS OTHERWISE SPECIFIED, ALL DIMENSIONS SHOWN ARE IN INCHES AND ALL TOLERANCES ARE TO BE: DEC. ± 0.005 ; FRAC. $\pm 1/64$; ANGLES $\pm 1/2^\circ$.
 2. UNLESS OTHERWISE SPECIFIED, WALL THICKNESS IS $.055$.
 3. UNLESS OTHERWISE SPECIFIED, BREAK ALL CORNERS $.015$ RADIUS.

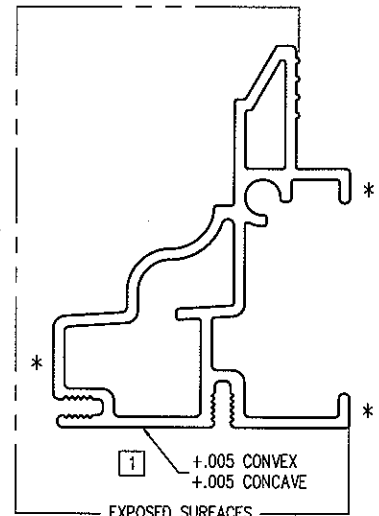
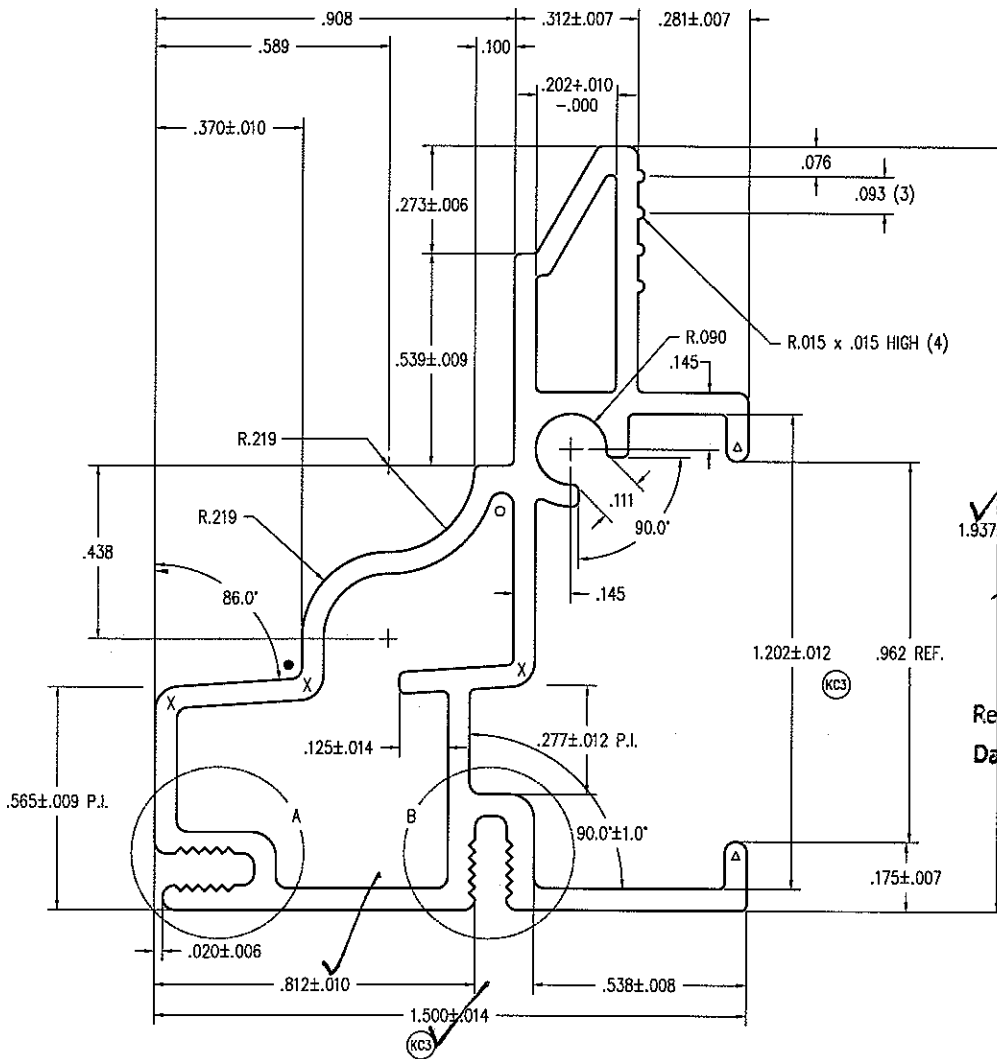

* = PERPENDICULAR WITHIN 1.0' TO FLAT SURFACE

1.937 ± 0.014

Architectural Testing

Test sample complies with these details. Deviations are noted.

Report# 71131

Date 3/15/07 Tech _____

- R .028 (12)
- R .031 (3)
- X R .062 (5)
- ▲ FULL RAD.(2)

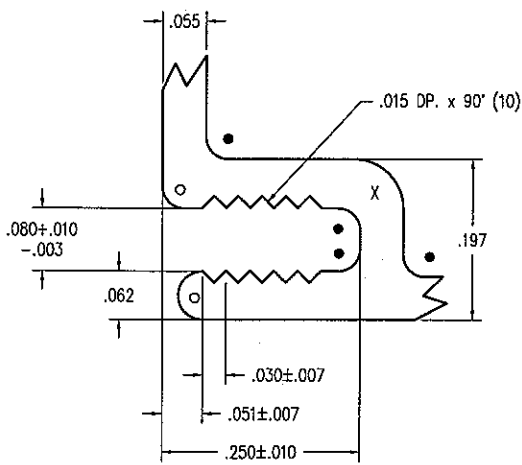

DETAIL "A"

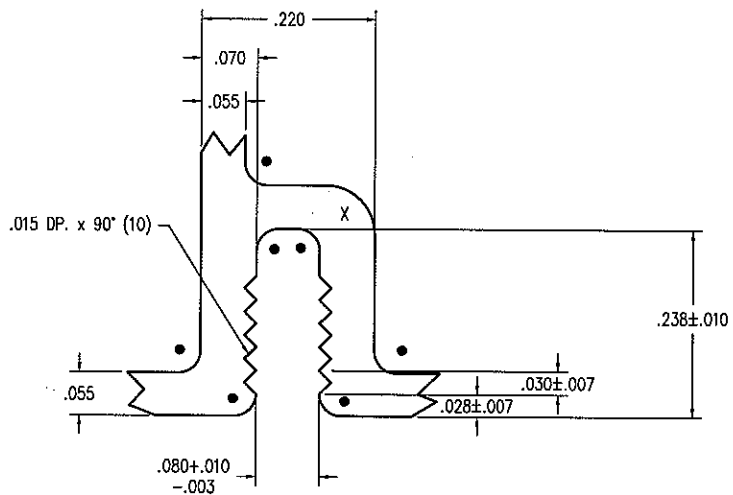

DETAIL "B"

THIS DRAWING AND ITS CONTENTS ARE THE PROPERTY OF EAGLE WINDOW & DOOR. NO USE OR REPRODUCTION OF THE CONTENTS OF THIS DOCUMENT IS PERMITTED WITHOUT THE EXPRESS WRITTEN PERMISSION OF EAGLE WINDOW & DOOR.
 TITLE: DH AUXILIARY FRAME CLADDING (W/ SCREW BOSS)
 FINISH: EAGLE'S STD. COLORS
 MATL: 6063 T-6 ALUMINUM

DFT: AWW SCALE: 2=1
 DCN: 0683 DRWG: A555
 DATE: 3/28/02 C 01 OF 03

NO	DESCRIPTION	DFT	DOC	DATE
01	ADDED/CHG'D DIM. & TOLERANCE	TWN	0778	4/4/03

Note: 1 UNLESS OTHERWISE SPECIFIED, ALL DIMENSIONS ARE SHOWN ARE IN INCHES AND ALL TOLERANCES ARE TO BE:
 DEC. +/- .005, FRACTION +/- 1/64, ANGLES +/- 1/2.



Test sample complies with these details.
 Deviations are noted.

Report# 71131
 Date 3/15/07 Tech PC

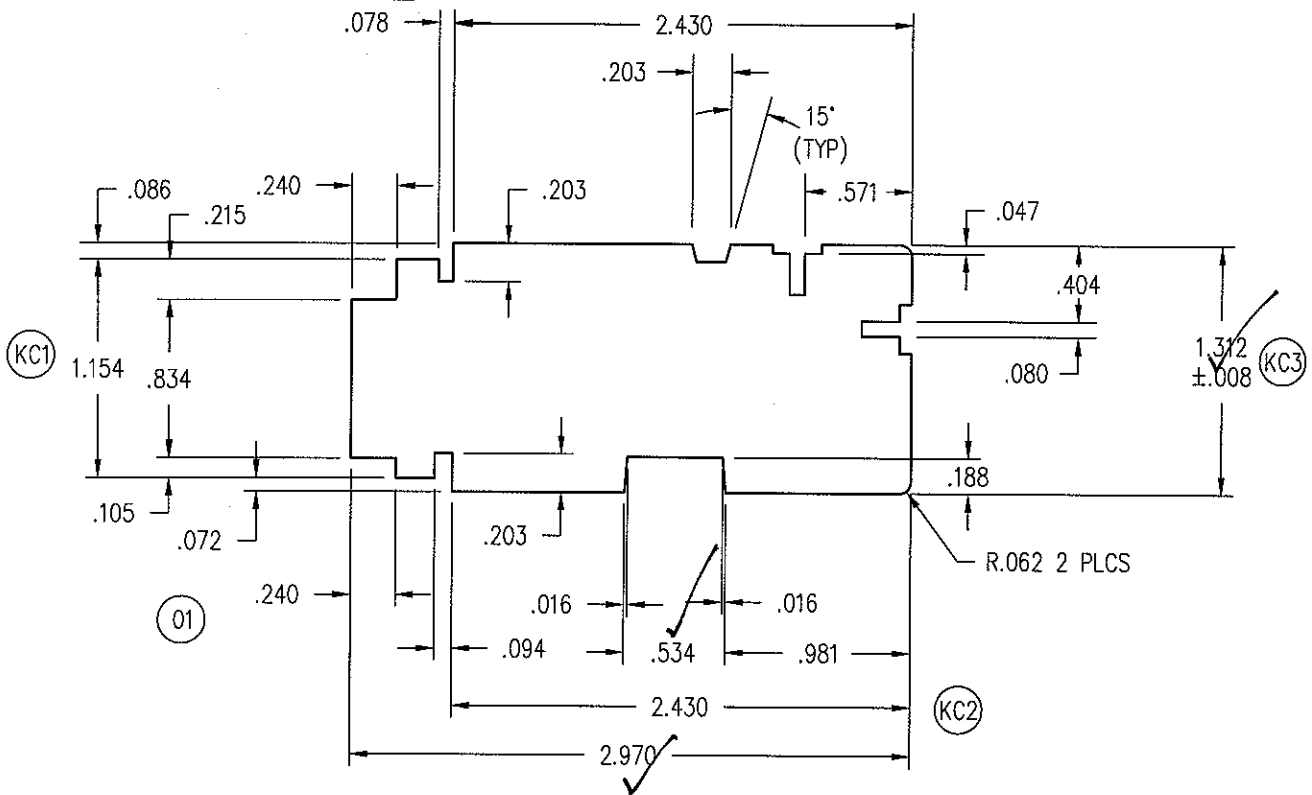
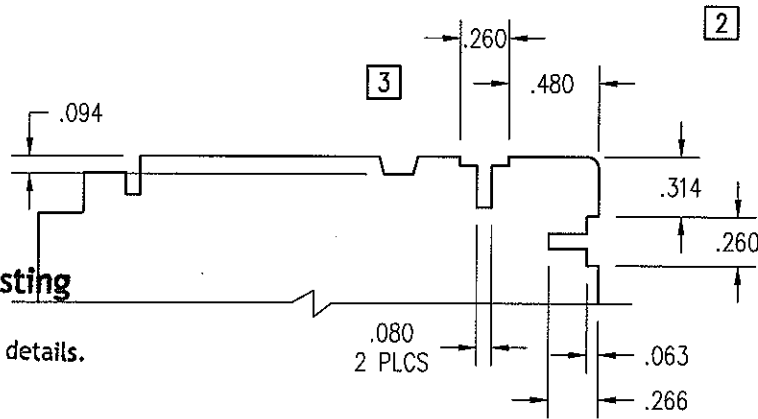

03	REMOVED 2 KERFS.	RDA	1005	12/05/05
02	REVISED PROFILE - ADDED CONCEALED FASTENER ROUT	RDA	0925	09/30/04
01	ADD .105 x .240 PLOW	AWW	0752	12/03/02
NO	Description of Change	Drafter	DCN#	Date

Title: AUXILIARY FRAME		Finish:	Material: SEE PAGE 02
Scale: 1=1	Date: 4/26/2002	THIS DRAWING AND ITS CONTENTS ARE THE PROPERTY OF EAGLE WINDOW & DOOR. NO USE OR REPRODUCTION OF THE CONTENTS OF THIS DOCUMENT IS PERMITTED WITHOUT THE EXPRESS WRITTEN PERMISSION OF EAGLE WINDOW & DOOR.	
Drafter: AWW	DCN# 0683		

- NOTE: 1. UNLESS OTHERWISE SPECIFIED, ALL DIMENSIONS SHOWN ARE IN INCHES AND ALL TOLERANCES ARE TO BE: DEC. ± 0.005 ; FRAC. $\pm 1/64$; ANGLES $\pm 1/2^\circ$.
2. VERTICAL SECONDARY STOPS WILL RUN THROUGH, HORIZONTAL SECONDARY STOPS WILL BUT UP TO THE VERTICAL SECONDARY STOP.
3. CAUX VERTICAL STOPS $L = \text{FRAME} - 2.625$
 CAUX HORIZONTAL STOPS $L = \text{FRAME} - 3.281$
 WAUX VERTICAL STOP $L = \text{FRAME} - 2.625$
 WAUX HORIZONTAL STOP $L = \text{FRAME} - 3.281$
4. FORMULAS SHOWN ARE FOR NOMINAL "A" DIMENSION TO EXTEND $3/16"$ PAST THE INTERIOR SURFACE OF THE JAMB BECAUSE OF THE NUMEROUS STOP AND GLASS CONFIGURATIONS STOPS HAVE BEEN COMBINED SO THE $3/16"$ DIMENSION MAY NOT ALWAYS HOLD TRUE.



Test sample complies with these details.
 Deviations are noted.

Report# 71131
 Date 3/15/07 Tech PC

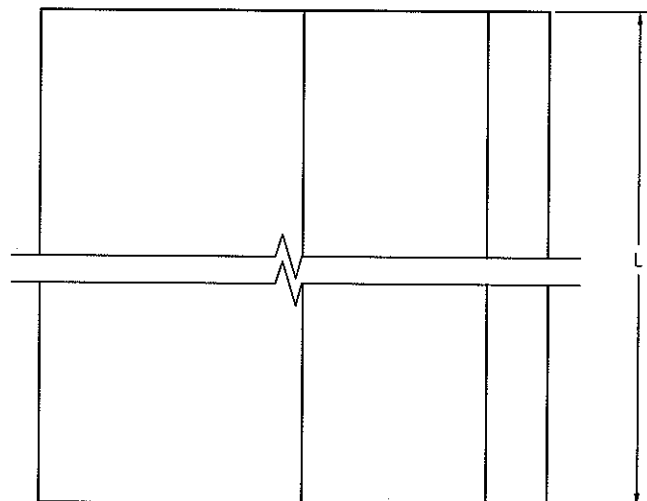
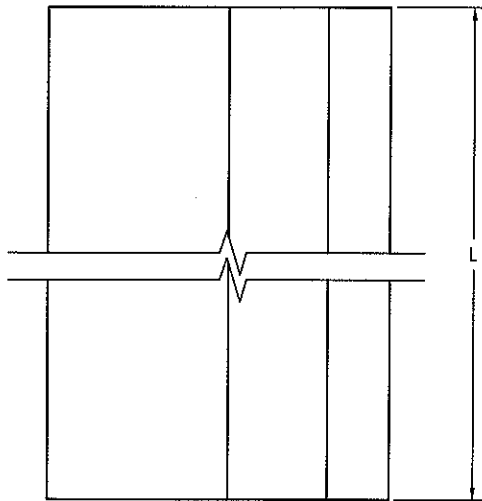
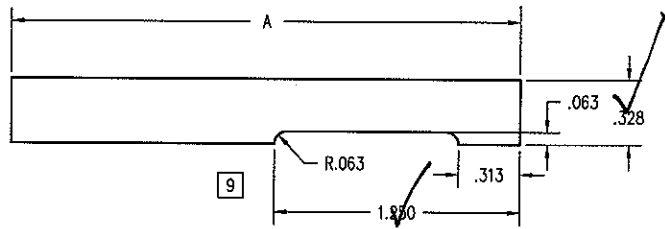
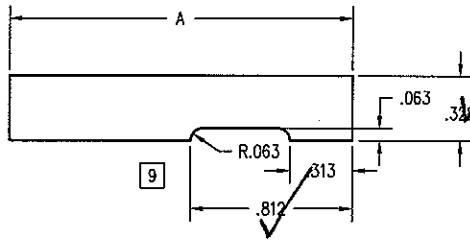

CHARTS BELOW SHOW THE "A" DIMENSION REQUIRED FOR SPECIFIED PRODUCTS AND SPECIFIC GLASS THICKNESS.

	DS	1/4"	11/32" IMPACT	15/32" IMPACT	3/4" GLASS	1" GLASS	1 3/16" GLASS
CLAD AUXILIARY	2 1/4"	2 9/64"	2"	1 29/32"	1 39/64"	1 23/64"	1 11/64"
WOOD AUXILIARY	2 37/64"	2 1/2"	2 23/64"	2 1/4"	1 29/32"	1 47/64"	

CLAD "COLONIAL", A = 2.343 - GLASS THICKNESS SEE NOTE #4
 WOOD "COLONIAL", A = 2.687 - GLASS THICKNESS

	DS	1/4"	11/32" IMPACT	15/32" IMPACT	3/4" GLASS	1" GLASS
CLAD EXTERIOR GLAZED AUX	2 1/2"	2 23/64"	2 1/4"	2"	1 47/64"	1 39/64"

EXT. GLAZED "COLONIAL", A = 2.549 - GLASS THICKNESS SEE NOTE #4

THIS DRAWING AND ITS CONTENTS ARE THE PROPERTY OF EAGLE WINDOW & DOOR. NO USE OR REPRODUCTION OF THE CONTENTS OF THIS DOCUMENT IS PERMITTED WITHOUT THE EXPRESS WRITTEN PERMISSION OF EAGLE WINDOW & DOOR.

TITLE: SECONDARY STOP
 AUXILIARY UNITS

FINISH:

MATL: EAGLE'S STD. WOOD SPECIES

09 CHANGED PROFILES	TWN 1057 10/30/06	DFT: GDE	SCALE: 1=1
08 REMOVED COPED INFORMATION	TWN 0910 04/20/05	DCN: 0229	DRWG: 203B
NO DESCRIPTION	DFT, DOC DATE	DATE: 2/27/1992	C 01 OF 01

NOTE: 1. UNLESS OTHERWISE SPECIFIED, ALL DIMENSIONS SHOWN ARE IN INCHES AND ALL TOLERANCES ARE TO BE: DEC. ±.005; FRAC. ±1/64; ANGLES ±1/2°.

PRODUCT	GLASS	A
(PRE '96 & NG) CLAD CASEMENT & AWNING	5/8"	.469
(PRE '96 & NG) CLAD CASEMENT PICTURE	3/4"	.469
CLAD PIANO HINGE CASEMENT	5/8"	.469
CLAD PIANO HINGE CASEMENT (3056 & ABOVE)	3/4"	.469
CLAD RADIUS CASEMENT	5/8" & 3/4"	.469
(PRE '96 & NG) CLAD DOUBLE / SINGLE HUNG	5/8"	.469
(PRE '96 & NG) CLAD DOUBLE HUNG PICTURE	5/8"	.469
CLAD DOUBLE HUNG TRANSOM	5/8"	.469
CLAD DOUBLE HUNG REPLACEMENT SASH	5/8"	.469
ALL CLAD (NON-RADIUS) AUXILIARY (0-15 SQ. FT.)	3/4"	.469
ALL CLAD (NON-RADIUS) AUXILIARY (15+ SQ. FT.)	1"	.469
CLAD SLIDING WINDOW	5/8"	.469
CLAD INSWING / OUTSWING FRENCH DOOR	3/4"	.469
CLAD FRENCH DOOR TRANSOM	3/4"	.469
CLAD PATIO / FRENCH SLIDING DOOR	3/4"	.469
(PRE '98) WOOD CASEMENT & AWNING	3/4"	.680
(PRE '98) WOOD CASEMENT PICTURE	3/4"	.680
(NG) WOOD CASEMENT & AWNING	5/8"	.469
(NG) WOOD CASEMENT PICTURE	5/8" & 3/4"	.469
WOOD PIANO HINGE CASEMENT	5/8"	.469
WOOD PIANO HINGE CASEMENT (3056 & ABOVE)	3/4"	.469
(PRE '96 & NG) WOOD DOUBLE / SINGLE HUNG	5/8"	.469
(PRE '96 & NG) WOOD DOUBLE HUNG PICTURE	5/8"	.469
WOOD SLIDING WINDOW	5/8"	.469
WOOD DOUBLE HUNG TRANSOM	5/8"	.469
WOOD DOUBLE HUNG REPLACEMENT SASH	5/8"	.469
WOOD (NON-RADIUS) AUXILIARY (0-15 SQ. FT.)	3/4"	.469
WOOD (NON-RADIUS) AUXILIARY (15+ SQ. FT.)	1"	.469
WOOD INSWING / OUTSWING FRENCH DOOR	3/4"	.469
WOOD FRENCH DOOR TRANSOM	3/4"	.469
WOOD PATIO / FRENCH SLIDING DOOR	3/4"	.469
CLAD & WOOD PATIO/FR. SLIDING DOOR (BLIND GLASS)	1"	.406
ALL CLAD AND WOOD WINDOWS AND DOORS EXCEPT AUXILIARY UNITS WHICH ALWAYS USES	SINGLE GLAZED H. MSTR MONO	.680



Test sample complies with these details
Deviations are noted.

Report# 7113
Date 3/15/07 Tech PC

PANEL STOPS	
PRODUCT	A
WOOD OUTSWING SIDELITE	.469
WOOD OUTSWING TRANSOM	.469
WOOD INSWING SIDELITE	.469
WOOD INSWING TRANSOM	.469

2

1

3

.062 x .062 CHAMFER

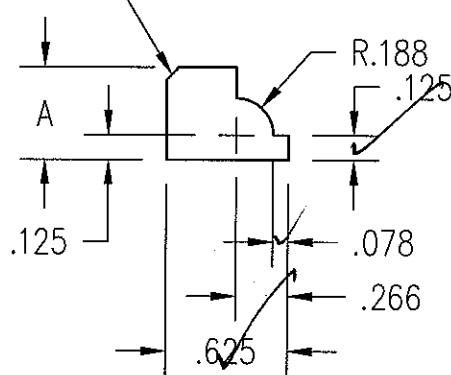

THIS DRAWING AND ITS CONTENTS ARE THE PROPERTY OF EAGLE WINDOW & DOOR. NO USE OR REPRODUCTION OF THE CONTENTS OF THIS DOCUMENT IS PERMITTED WITHOUT THE EXPRESS WRITTEN PERMISSION OF EAGLE WINDOW & DOOR.

TITLE: COLONIAL GLAZING STOP

FINISH:

MATL:

EAGLE STD WOOD OFFERINGS

03	ADDED SIZE FOR IMPACT GLAZING	TWN	0972	9/1/05		
02	CHG'D CLAD PANEL STOP "A" DIM	JH	0794	6/30/05	DFT: JMH	SCALE: 1=1
01	ADDED KYLER BLIND SIZE	TWN	0910	4/19/05	DCN: 0650	DRWG: 220J
NO	DESCRIPTION	DFT	DOC	DATE	DATE: 5/29/2002	A 01 OF 03