

Eagle® Profiled Exterior Casing Assembly Instructions

These instructions are for the assembly of profiled exterior casing and sill nosing to Eagle windows and doors.

Carefully follow these instructions for assembly at the jobsite. Installation instructions for Eagle windows and doors are available online at EagleWindow.com.

Please read the following instructions thoroughly before starting.

PARTS INCLUDED

Casing (with nail fin and casing connectors)	
End Caps	Sill Shims
Corner Keys	#6 x 3/4" Embossing Screws
Foam Corner Seal	#6 x 3/4" Self-tapping Screws

TOOLS REQUIRED

Safety Glasses	Scissors
Caulk Gun	Pliers
Drill/Driver	Hammer
Staple Gun	Miter Saw
Tape Measure	Hacksaw
Flat-head Screwdriver	#2 Phillips Screw Bits

SUPPLIES REQUIRED

Gloves	Tape
Clean Rag	3/8" Staples
Wood or Nylon Block	High-quality Exterior-grade Sealant

⚠ WARNING

Metal fasteners and other hardware components may corrode when exposed to preservative treated and fire-retardant treated lumber. Obtain and use the appropriate metal fasteners and hardware as called out by the installation guide to fasten unit to any rough opening made from pressure treated and fire-retardant treated lumber. Failure to use the appropriate materials for the installation may cause a failure resulting in injury, property or product damage.

GENERAL WARNINGS AND CAUTIONS

Read and follow warnings and cautions during the assembly process. Safety should always come first.

⚠ WARNING

Windows and doors can be heavy. Use safe lifting techniques and a reasonable number of people with enough strength to lift, carry and install window and door products to avoid injury and/or product damage.

⚠ WARNING

Use caution when working at elevated heights and around unit openings. Follow manufacturers' instructions for ladders and/or scaffolding. Failure to do so may result in injury or death.

⚠ WARNING

Do not carry or lift unit by extension jambs or casings. Doing so may result in injury, product or property damage.

⚠ WARNING

Unless specifically ordered, Eagle windows and doors are not equipped with safety glass, and if broken, could fragment causing injury. Many laws and building codes require safety glass in locations adjacent to or near doors. Eagle windows are available with safety glass that may reduce the likelihood of injury when broken. Information on safety glass is available from your local Eagle dealer.

⚠ WARNING

Follow manufacturers' instructions for hand or power tools. Always wear safety glasses. Failure to do so may result in injury and/or product damage.

CAUTION

Follow instructions of foam, sealant and flashing manufacturer regarding material application and compatibility with this product.

GLASS

Tempered or laminated safety glass is not standard and must be special ordered. Check local building codes.

Leave protective film in place until after construction is finished. Leave (NFRC) performance label in place until final inspection or for homeowner's use/records.

Protective film and exterior coating are not present on all units.

⚠ WARNING

Suction grips will not hold if placed over seam of film to lift or move unit. Unit will fall causing damage or injury.



CAUTION

Sealants will damage exterior coating on glass.



FINISHING

CAUTION

- Finish wood surfaces immediately after installation. Unfinished wood will deteriorate, discolor, and/or may bow and split.
- Do not stain or paint weather strip, vinyl, glass or hardware. Product damage may occur.

- ▶ Film is not a substitute for masking.
- ▶ Finish all hidden wood surfaces.
- ▶ Read and follow finishing product instructions and warnings on finish material.

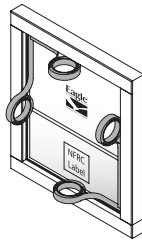

FILM REMOVAL

Starting from a seam or corner of the film (using a plastic scraper if needed), remove the protective film from the glass surface.

Remove protective film within nine months of installation and when temperature is above 32° F.

⚠ WARNING

Dispose of film immediately after removing. Film may pose suffocation hazard to children.

⚠ WARNING

Static created when removing film can ignite flammable materials or cause a shock, and can pass through the other side of the glass. See warning label on glass.

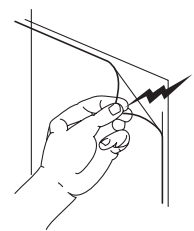

CLEANING

Clean glass using liquid glass cleaner.

Clean exterior frame, sash, and insect screens using mild detergent and water with a soft cloth and brush.

For hard to clean areas use a nonabrasive cleaner, alcohol-and-water or ammonia-and-water.

CAUTION

- Abrasive cleaners will damage glass surface.
- Metal razor blades can damage glass surface and exterior coating.
- Acid solutions used for cleaning masonry or concrete will damage glass, fasteners, hardware, and metal flashing. Protect unit and follow cleaning product instructions carefully. If acid contacts unit, wash all surfaces with water immediately.

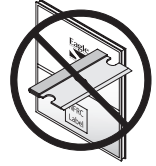

MAINTENANCE

Do not apply any type of film to insulating glass. Thermal stress and glass damage can result. Shading devices (insulated coverings, shutters, etc.) may also cause thermal stress and condensation damage.

For more information, contact your Eagle dealer.

⚠ WARNING

Do not install air conditioner in window. Injury and/or product or property damage may occur.



STEP 1

Casings and installation styles.

Determine the type of the exterior casing to be used with your Eagle window and door products and the style of installation.

TYPE OF PROFILED EXTERIOR CASING

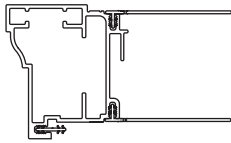

Brickmold Casing
A753

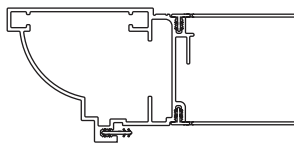

Exterior Casing
A754

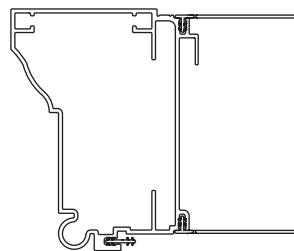

Exterior Casing
A755

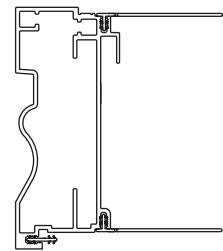

Exterior Casing
A756

TYPE OF SILL NOSING

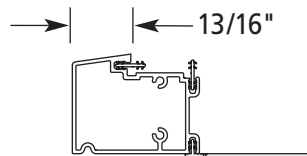

Sill Nosing - A751

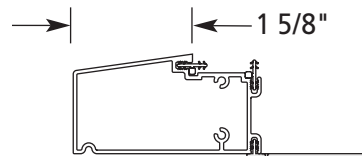

Sill Nosing - A752

INSTALLATION STYLES

Note: The icons below represent the specific styles of casing installations available (see detail at right).

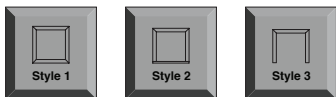

Look for these throughout the assembly steps to assist in understanding what styles of installation pertain to each step.

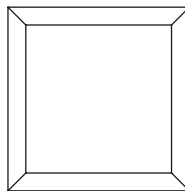

Style 1

Casings located
on all sides

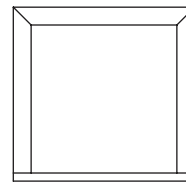

Style 2

Casings located
on head and sides
(sill nosing included)

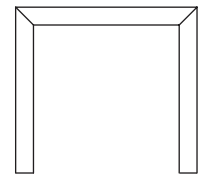

Style 3

Casings located
on head and sides
(sill nosing not included)

STEP 2

Review cutting guidelines.

Cutting profiled casing with a chop saw.

Because of the nail fins and the complicated profiles, it is difficult to cut the casing when the nail fin is attached and still produce a good, precise miter cut. With this in mind, see the suggestions below on how to position the casing in the chop

saw. When folding the nail fin over, it is best to tape the nail fin down to hold in place. You must cut the casing slowly or there is the potential to shatter the nail fin vinyl. Always wear safety glasses and work gloves when cutting the exterior casings.

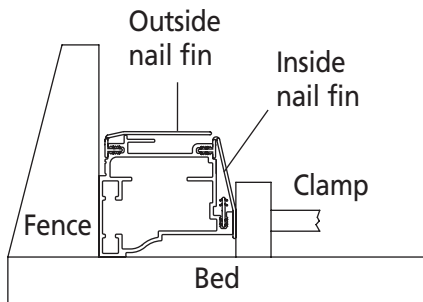

Brickmold Casing
A753

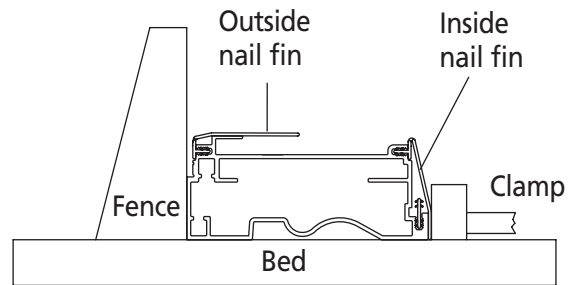

Exterior Casing
A756

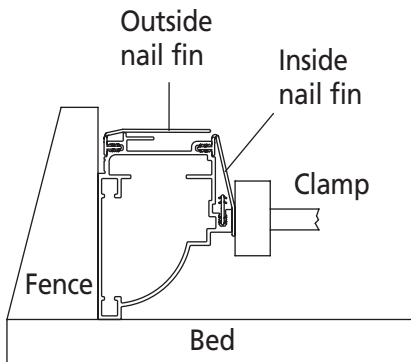

Exterior Casing
A754

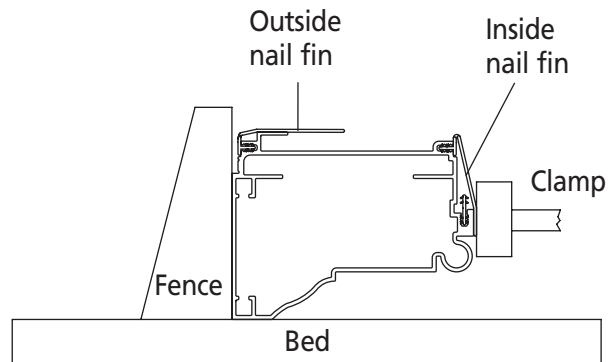

Exterior Casing
A755

STEP 3

Cut head casing to length.

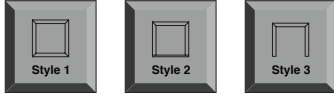

Cut the head profiled casing to correct length using a 45° miter at each end using the cutting guidelines from Step 2. Correct head length is determined by type of casing being used.

- A753 Brickmold: Head Length = Frame Width + 3 9/32"
- A754 Casing: Head Length = Frame Width + 3 9/32"
- A755 Casing: Head Length = Frame Width + 6 17/64"
- A756 Casing: Head Length = Frame Width + 6 17/64"

If Installation Style 1, two pieces will be required. Otherwise one piece of head casing is required.

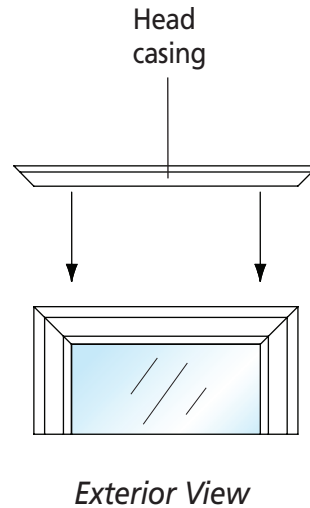

STEP 4

Cut sill nosing to length.



If Installation Style 1 or 3, skip to Step 5.

Cut sill nosing to length with a straight cut at each end.

- A753 Brickmold casing: Length = Frame Width + 3 5/32"
- A754 Profiled casing: Length = Frame Width + 3 5/32"
- A755 Profiled casing: Length = Frame Width + 6 9/64"
- A756 Profiled casing: Length = Frame Width + 6 9/64"

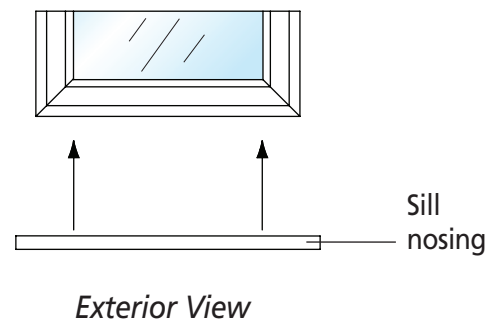

STEP 5

Cut jamb casing to length.

Jamb length and cut angle is dependent on style of installation. Left and right side jams required.

Installation Style 1



Cut left and right jamb casing with a 45° miter cut at each end.

A753 Brickmold casing: Jamb Length = Frame Height + 3 5/16"

A754 Profiled casing: Jamb Length = Frame Height + 3 5/16"

A755 Profiled casing: Jamb Length = Frame Height + 6 19/64"

A756 Profiled casing: Jamb Length = Frame Height + 6 19/64"

Installation Style 2



Cut left and right jamb casing with a 45° miter cut at head end and an 8 1/2° bevel cut at the sill end.

A753 Brickmold casing: Jamb Length = Frame Height + 1 1/2"

A754 Profiled casing: Jamb Length = Frame Height + 1 5/8"

A755 Profiled casing: Jamb Length = Frame Height + 3 1/8"

A756 Profiled casing: Jamb Length = Frame Height + 2 31/32"

Installation Style 3



Cut left and right jamb casing with a 45° miter cut at head end and a straight cut at the sill end.

A753 Brickmold casing: Jamb Length = Frame Height + 1 21/32"

A754 Profiled casing: Jamb Length = Frame Height + 1 21/32"

A755 Profiled casing: Jamb Length = Frame Height + 3 5/32"

A756 Profiled casing: Jamb Length = Frame Height + 3 5/32"

Exterior Views

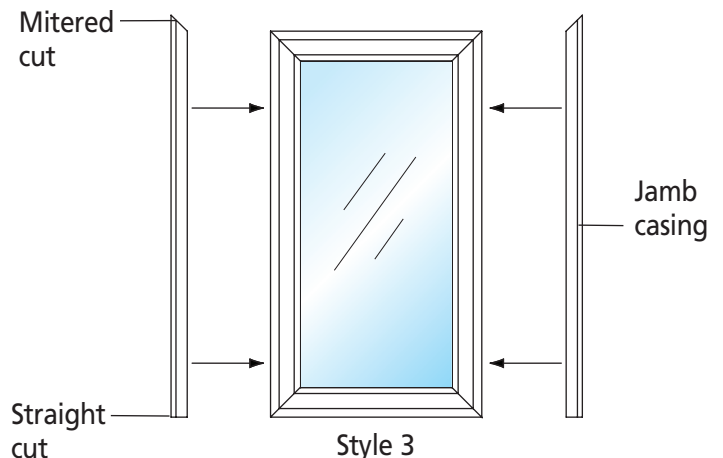
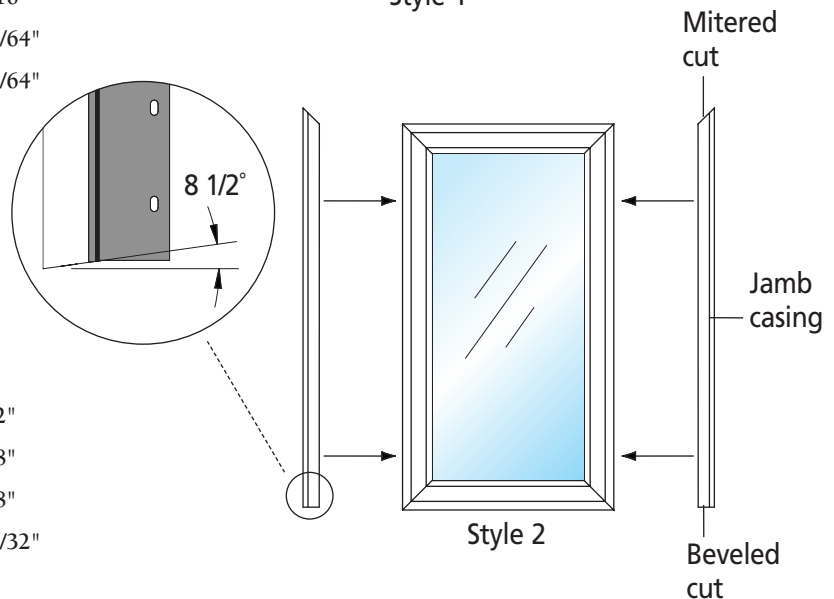
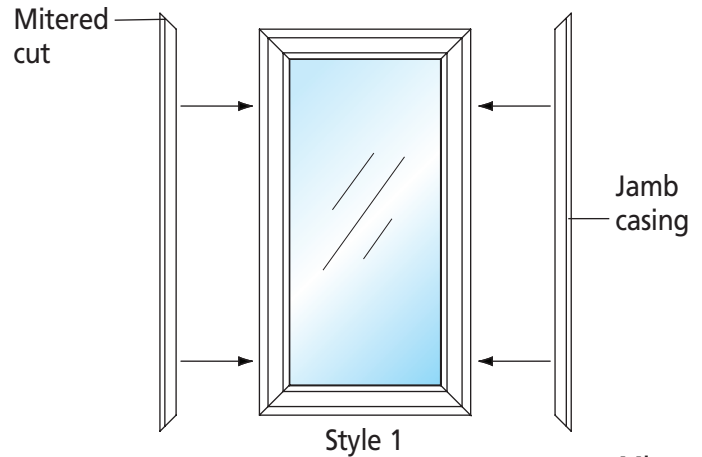

STEP 6

Preparing head casing for assembly.

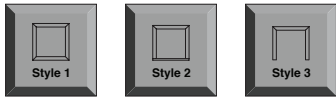

Insert two zinc corner keys in each end of the head casing. Press key into the square opening and fully seat by tapping lightly with a hammer.

Insert foam corner seal into back channel of extrusion.

If Installation Style 1, prepare sill casing as well.

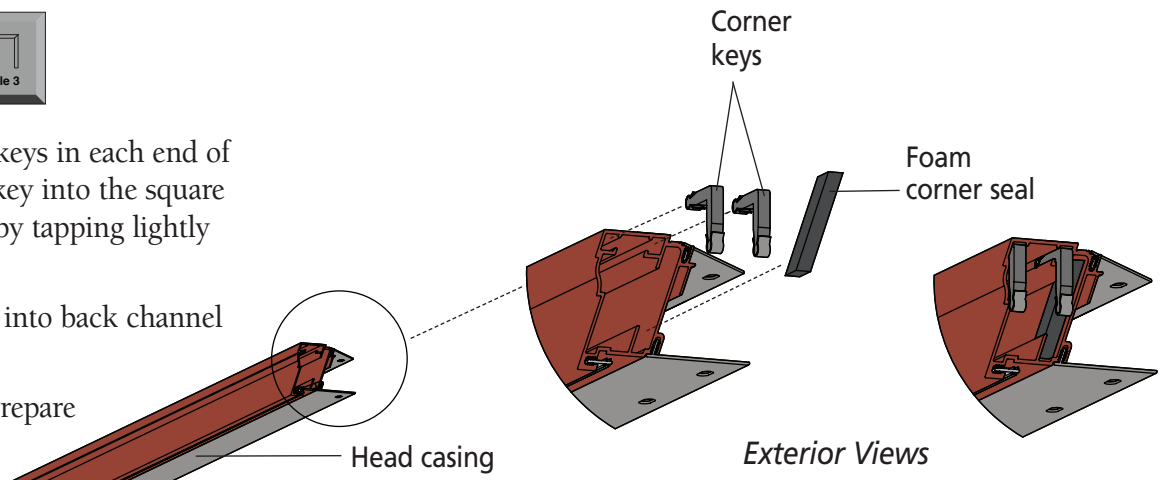

STEP 7

Prepare jamb casing for assembly.

Jamb casing prep is dependent on style of installation. Left and right side jambs are required.

Installation Style 1

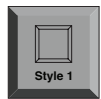

Insert foam corner seal into back channel of extrusion at each end of jamb casing keeping it flush with the end of the casing.

Installation Style 2

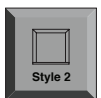

Insert foam corner seal at the top or head end of the jamb casing. Insert foam corner seal at the bottom or sill end of the jamb casing. Seals are located in the back channel of the extrusion as shown.

(A752 when used in conjunction with A754 or A755 exterior casing): Insert corner key into square slot as shown - leave a 1/4" gap between key and bottom of casing.

Installation Style 3

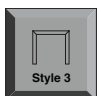

Insert a foam corner seal at the top or head end of the jamb casing.

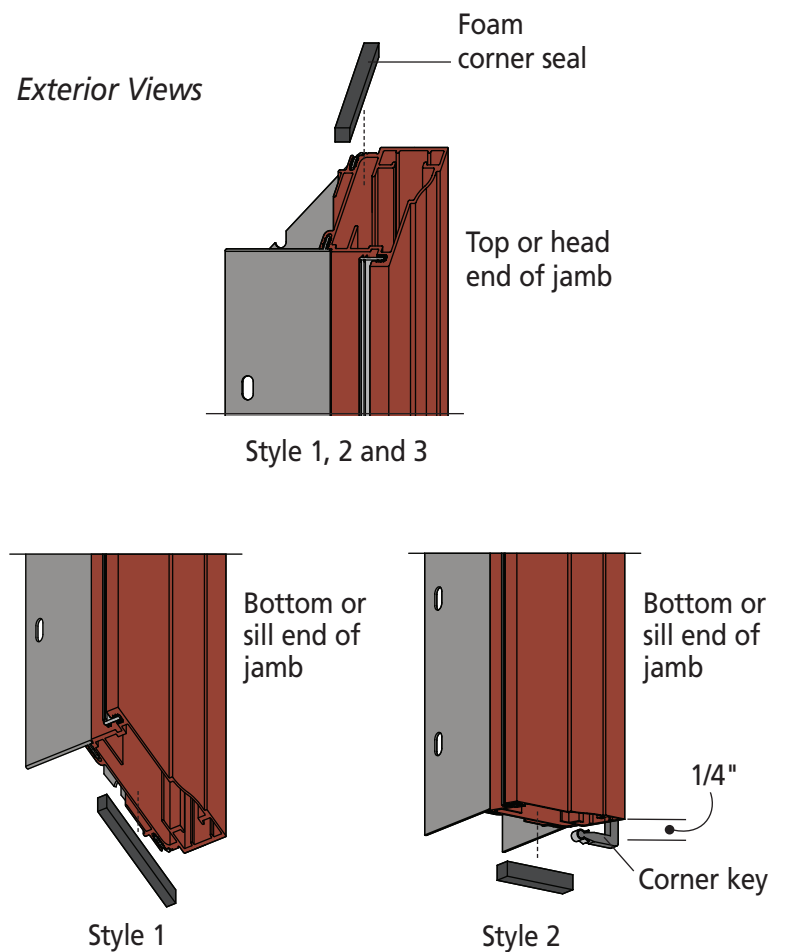

(Corner key needed only when A752 sill nosing is being used in conjunction with A754 or A755 exterior casing)

STEP 8

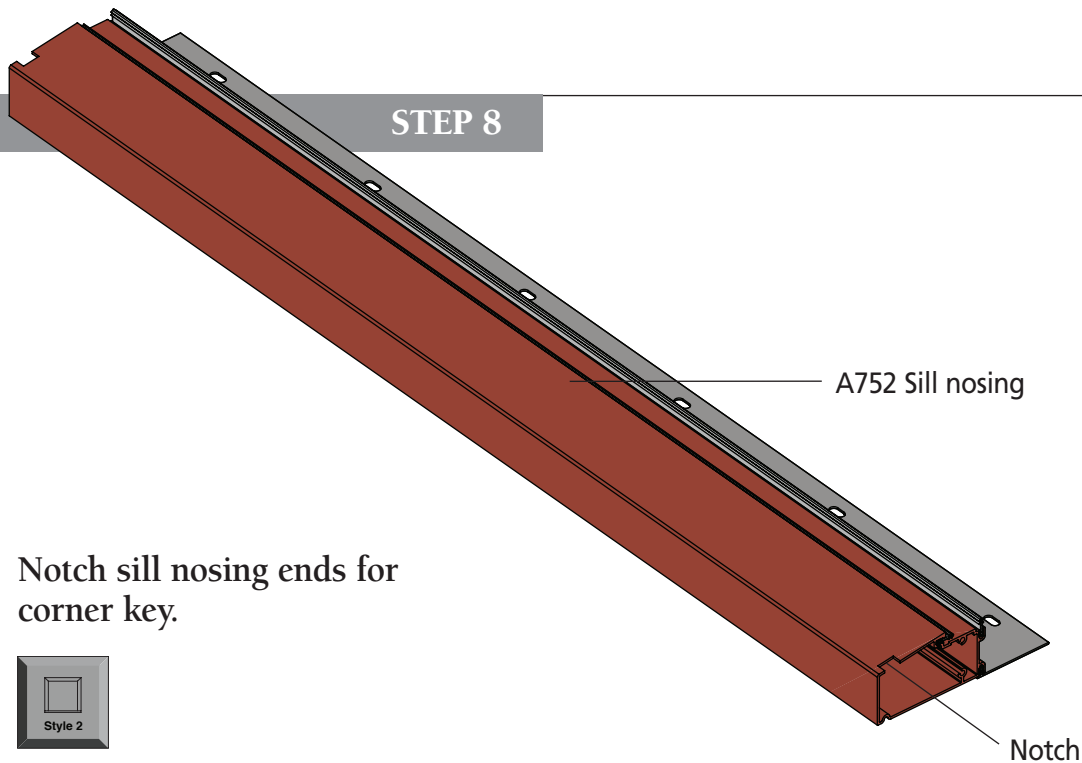

Notch sill nosing ends for corner key.



This is only required when A752 sill nosing is used in conjunction with A754 or A755 exterior casing, otherwise skip to Step 9.

See template attached at end of instructions for notching instructions.

Carefully cut out each template with a scissors.

Line up each template with its respective end as illustrated. Fold at the dotted lines and tape to the sill nosing.

With a hacksaw, make two precise parallel cuts $7/32$ " in length on the top edge of the sill nosing as illustrated.

Then take a pliers between the two cuts and gently bend back and forth to snap off the center section to create the notch.

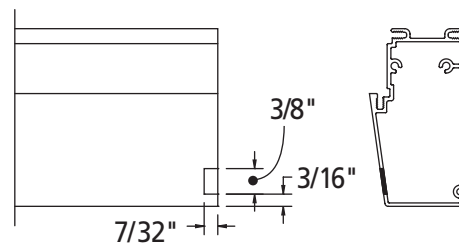

Notch on A752 sill nosing when used in conjunction with A754 and A755 exterior casing
(see template)

STEP 9

Assemble head and jamb casing.

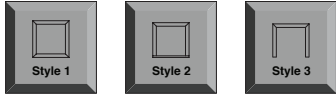

Apply a 3/8" diameter bead of sealant over the foam corner seal at each end of head casing.

Laying the head casing upside down and flat on a hard surface with the corner keys pointing up, align the corner key receivers of the side jamb casing with the head corner keys. Press together. While applying pressure, work the jamb back and forth until the head and jamb casing make a tight fit. Repeat for other jamb.

For Installation Style 1, repeat steps for sill casing.

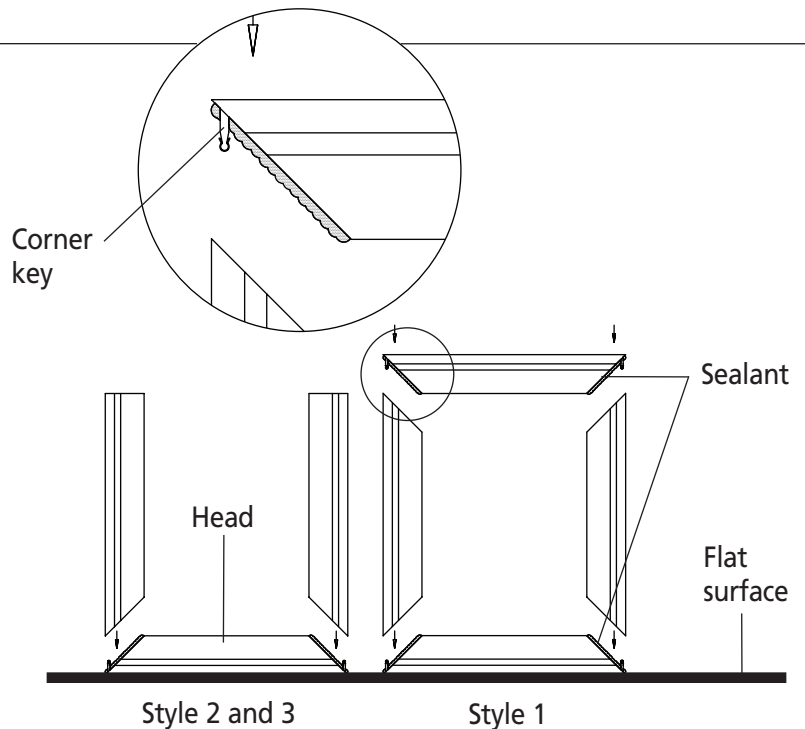

Exterior Views

STEP 10

Attach sill nosing to unit (A751 or A752).



If Installation Style 1 or 3, skip to Step 14.

Center sill nosing on unit sill. Rotate sill nosing slightly, inserting the outside casing connector in the outside receiver of the sill. Push sill nosing down towards unit and rotate back up to seat the inside casing connector into the nail fin receiver on the unit. Use a hammer and wood or nylon block to seat sill nosing if required.

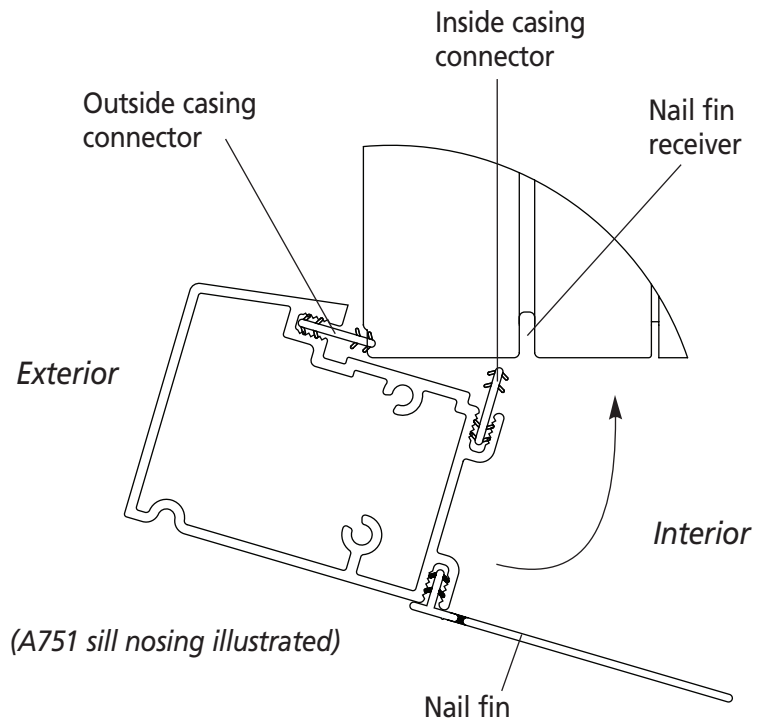

STEP 11

Seal sill nosing to unit (A751 or A752).



Apply a 1/4" diameter bead of sealant along the outside edge of the inside casing connector. Run bead to the unit edge and then out to the front receiver of window as shown. Then run a bead 3" up the side of the unit on the outside edge of the nail fin receiver. Repeat step on other side.

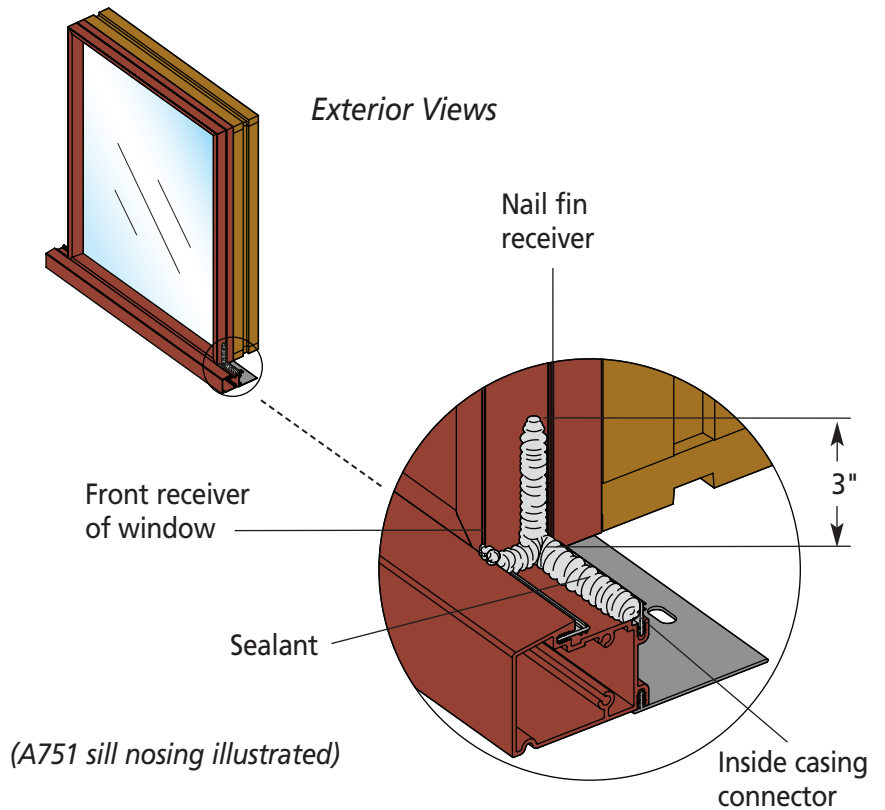

STEP 12

Attach sill shims to sill nosing (A751 or A752).



Position sill shim with the thin nose pointed towards the exterior and the kerf at the bottom. Align the front kerf of shim to the outside casing connector. Push shim into the connector and then down to fit over inside casing connector. Repeat for other side of sill.

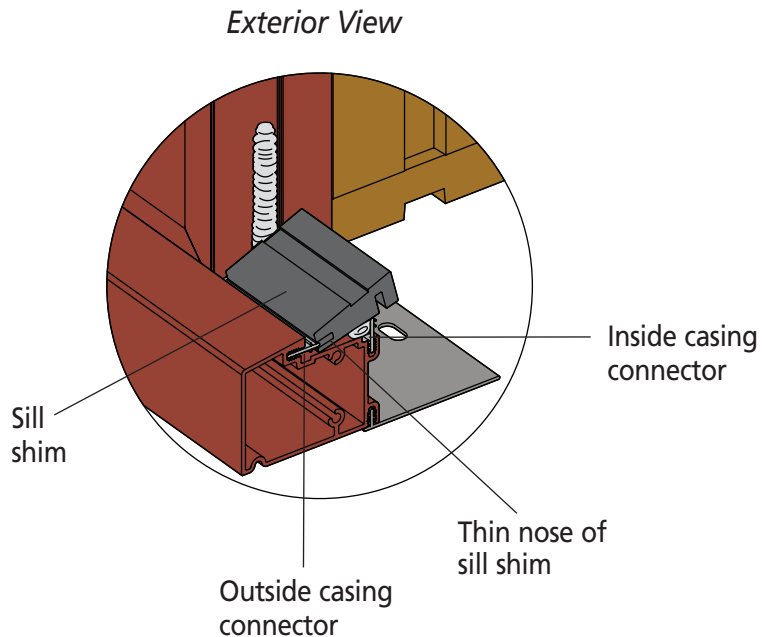

STEP 13

Apply sealant to shim
(A751 or A752).



Apply a 1/4" bead of sealant to the top of the sill shim from the unit to the end of the sill shim. Repeat for other side.

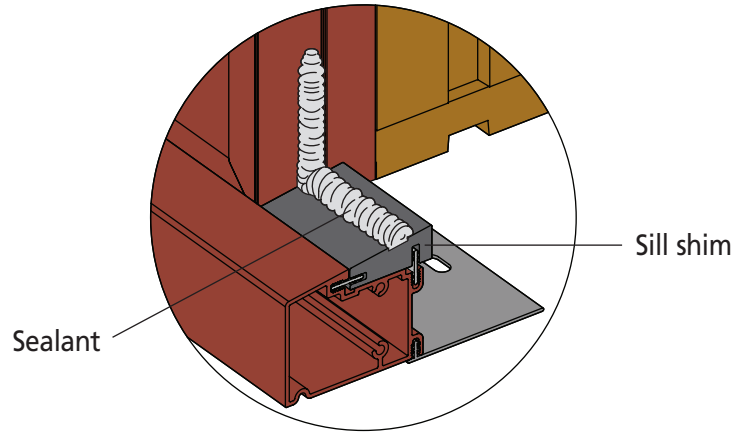

(A751 sill nosing illustrated)

STEP 14

Apply sealant to casing.



Apply a 1/4" diameter dot of sealant to each interior (back) side corner of the casing where the head and the jamb casing connectors meet.

If Installation Style 1, apply dot of sealant at all four corners as per the above instructions.

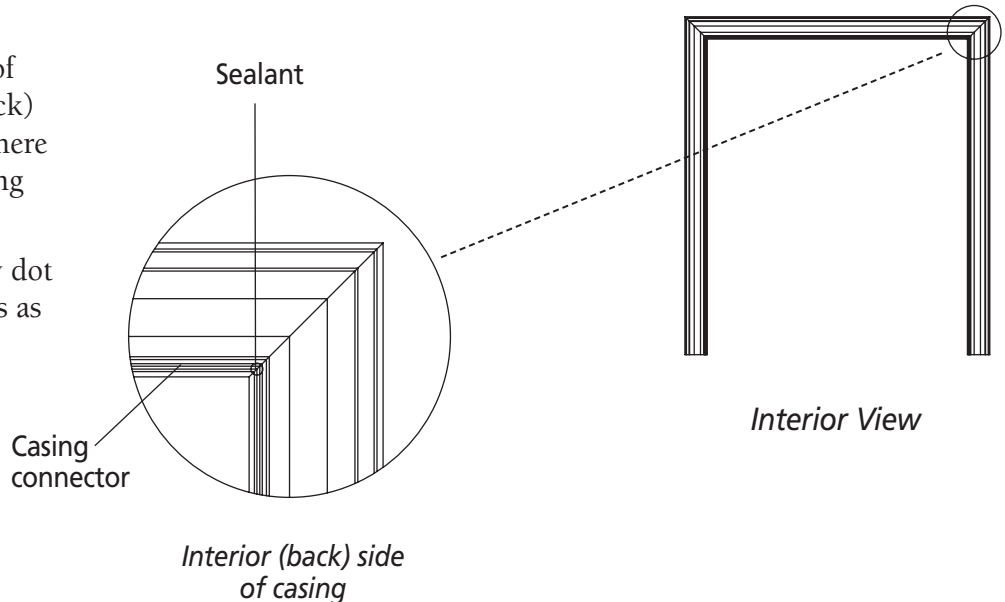

STEP 15

Attach casing assembly to unit.

Place window exterior side up on a clean, flat surface.

Installation Style 2

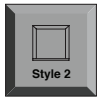

(A751) At the sill end of the assembly, insert the casing connector of the jamb casing into the front receiver of the unit as close to the sill as possible. Push the casing assembly down towards the unit and the sill nosing until the head casing connector will fit into the front head receiver of the unit.

(A752 when used in conjunction with A754 or A755 exterior casing) Hook the corner keys from each jamb of the jamb casing assembly into the notches of the A752 sill nosing as shown. Insert the casing connector on the jamb casing into the front receiver of the unit as close to the sill as possible. Push the casing assembly down towards the unit and the sill nosing until the head casing connector will fit into the front head receiver of the unit.

Once the connector is started all around the unit, use a wood or nylon block and hammer to gently tap casing down to fully seat connector in receiver of unit.

Style 2
(shown with A752
sill nosing and
A755 casing)

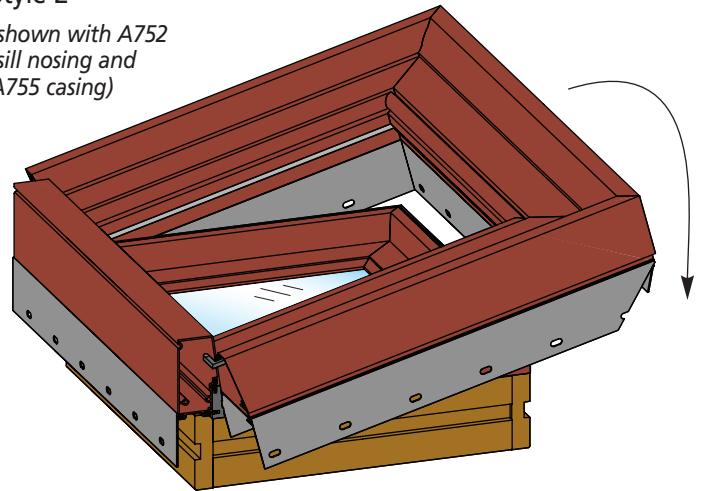

Exterior View

Installation Style 1 and 3



Line up the casing connectors of the casing assembly with the front receivers of the unit.

Once the connectors are started all around the unit, use a wood or nylon block and hammer to gently tap casing down to fully seat connectors in receivers of unit.

Style 1

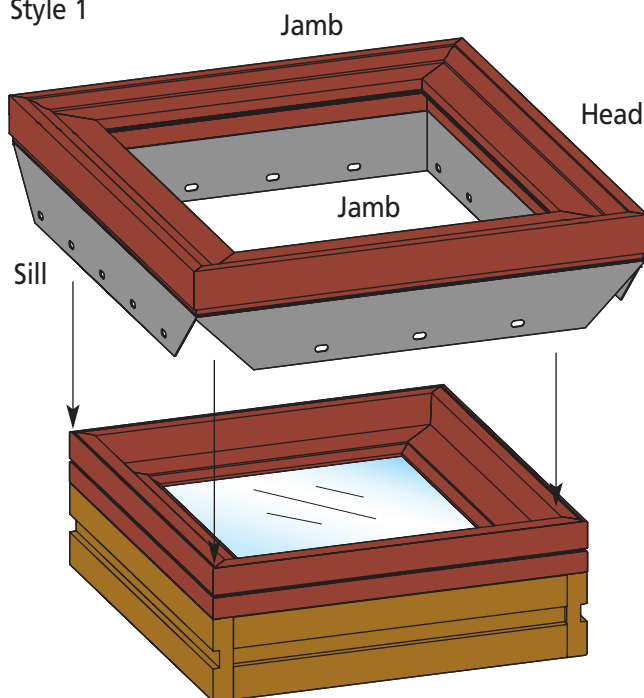

Style 3

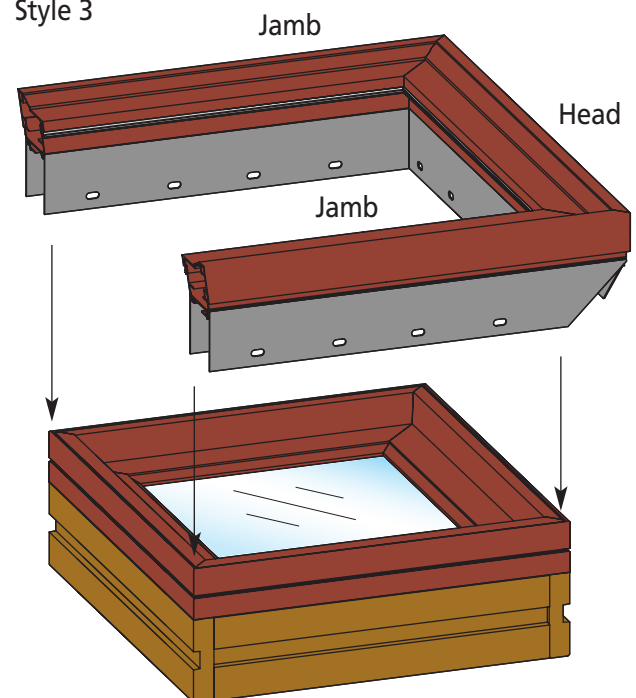

Exterior Views

STEP 16

Staple interior nail fin to unit.

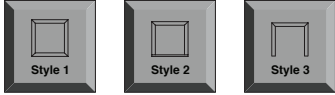

Using a 3/8" to 5/8" length staple, staple the inside nail fin to the unit frame. Start 1" from each end of nail fin and space staples approximately 10 - 12" on centers.

Assembly is now complete for Installation Style 1 and 3.

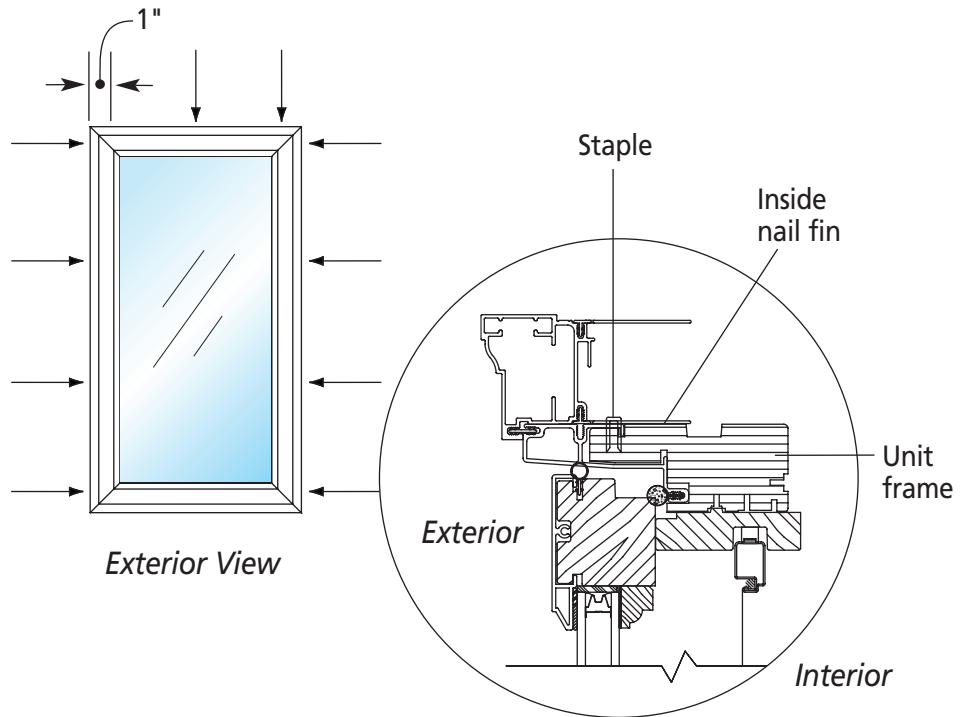

STEP 17

Secure sill nosing to side casing with corner key.



NOTE: Only when A752 is used in conjunction with A754 or A755 exterior casing, otherwise skip to Step 18.

Place the flat head of a screw driver at the bottom of the corner key. Lightly tap the screw driver to force the corner key up tight to the sill nosing.

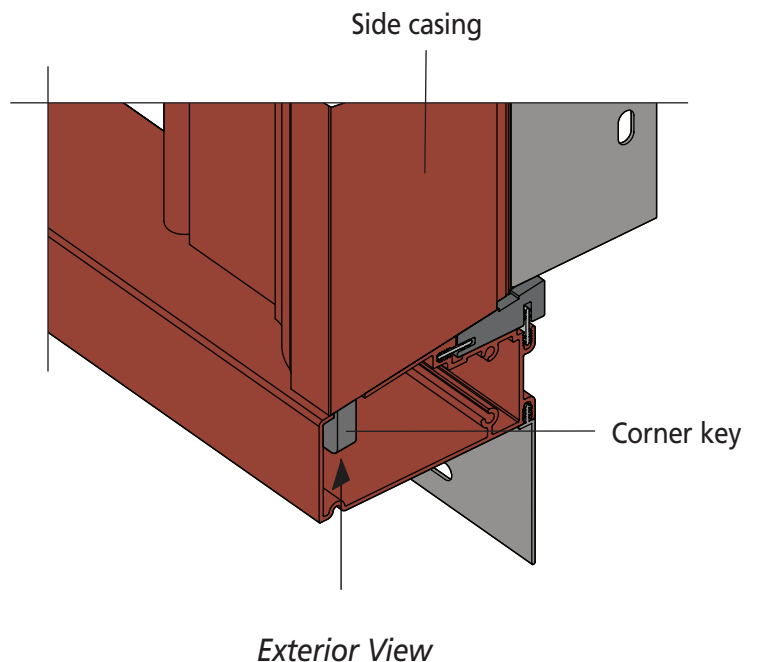

STEP 18

Attach sill nosing end caps (A751 or A752).



Apply a 1/8" diameter bead of sealant around the edge of the sill nosing extrusion leaving a gap for drainage, as shown.

Align the end cap with the sill nosing extrusion. Use two #6 x 3/4" embossing screws to attach the end cap to the sill nosing.

Use a #6 x 3/4" self-tapping screw to screw the end cap to the jamb casing.

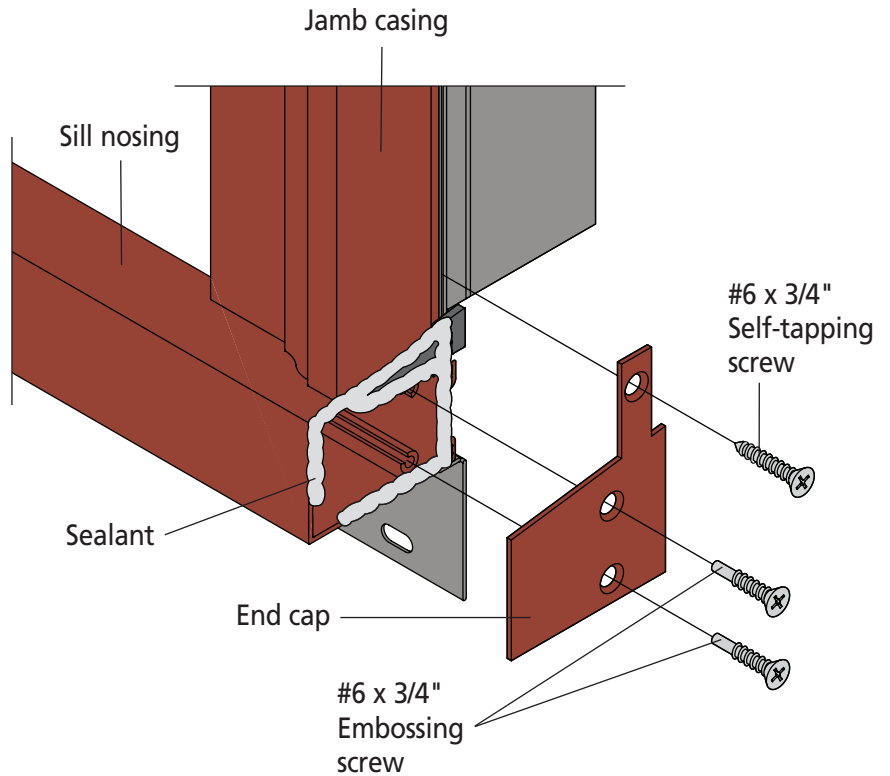

Assembly is now complete for Installation Style 2.

PRODUCT INSTALLATION DETAILS

For product installation information, please refer to the installation instructions at EagleWindow.com

SECTION DETAIL - BRICK EXTERIOR APPLICATION

[Head Detail]

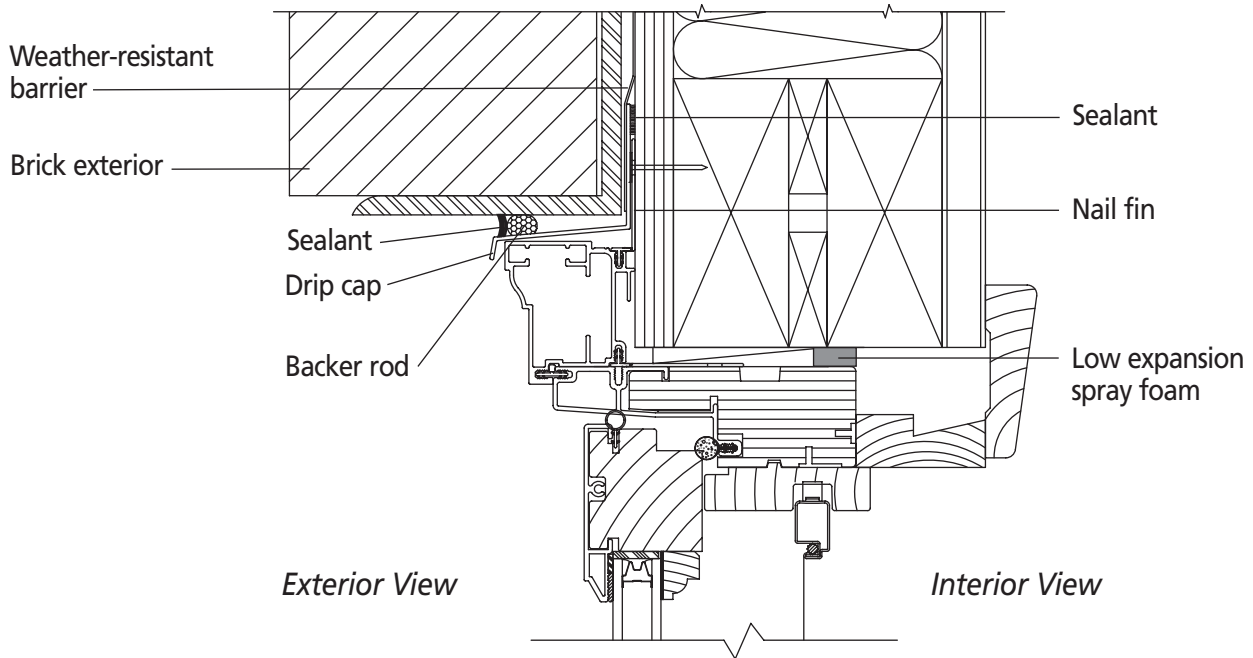

SECTION DETAIL - WOOD SIDING AND TRIM APPLICATION

[Head Detail]

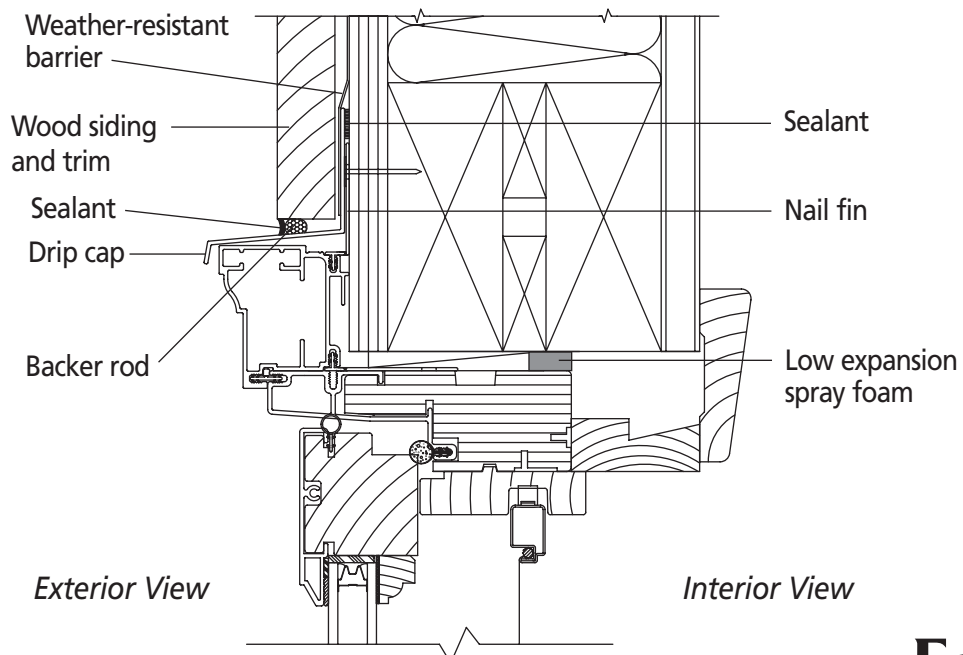

Notch for A752 Sill Nosing when using A754 or A755 Profiled Casing

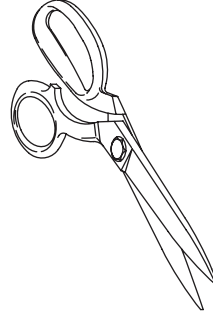
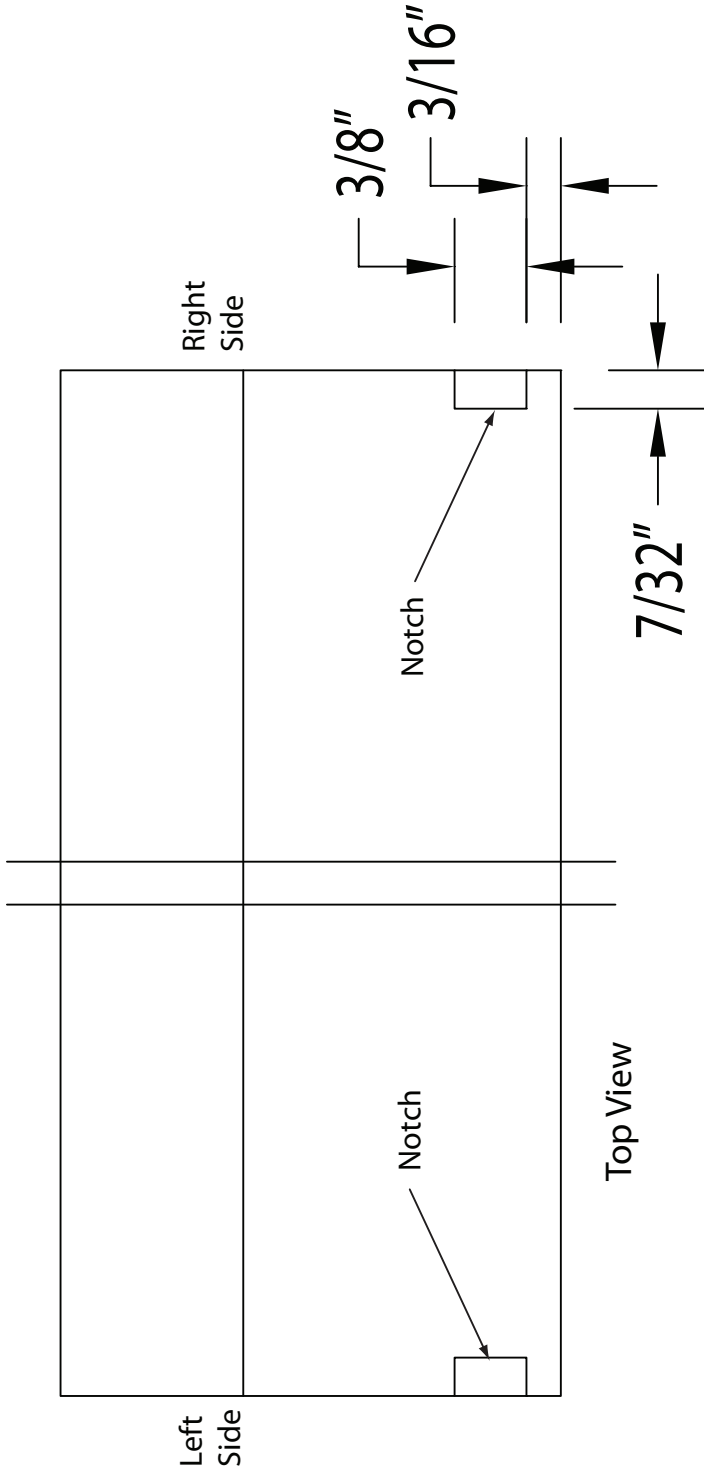

1. Make sure templates were printed at 100% size. Carefully, cut out each template with a scissors.

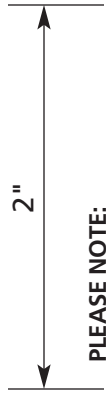

PLEASE NOTE:

If template was printed from the Eagle® website or from an electronic file, check 2" measurement above to make sure template size has not been altered.

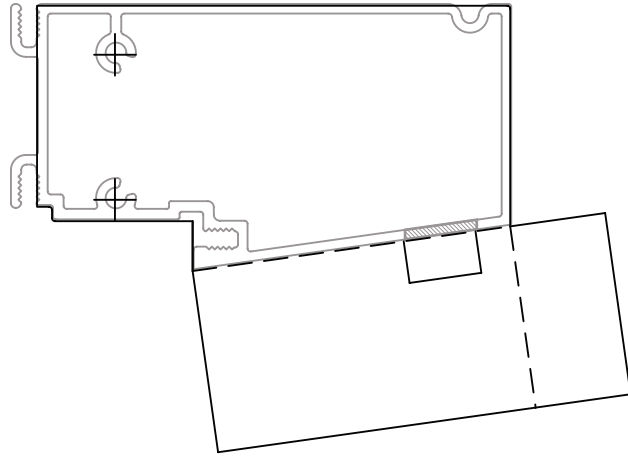

2. Line up each template with its respective end as illustrated. Fold at the dotted lines and tape to the sill nosing

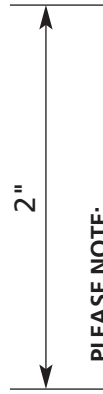

PLEASE NOTE:

If template was printed from the Eagle® website or from an electronic file, check 2" measurement above to make sure template size has not been altered.

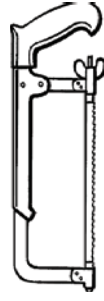

3. With a hacksaw, make two precise parallel cuts $7/32$ " in length on the top edge of the sill nosing as illustrated.

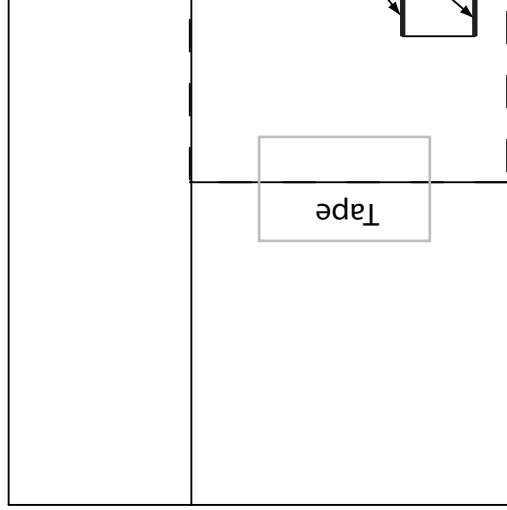

Top View

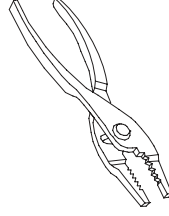

4. Then take a pliers between the two cuts and gently bend back and forth to snap off the center section to create the notch.

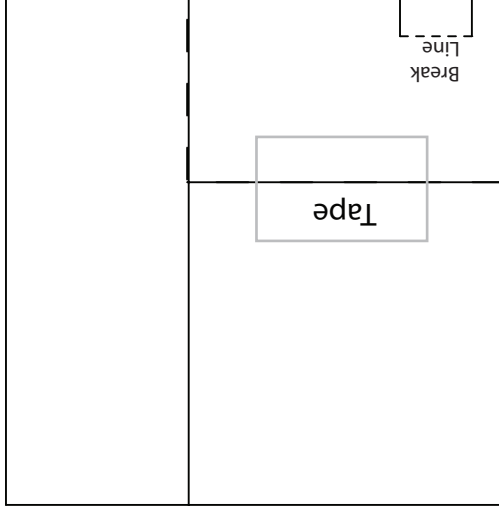

Top View

See the Caring for Eagle Windows and Doors guide for additional care and maintenance information.

Methods and procedures for installation of siding and other cladding materials, trim, moldings and other finish materials around window openings are not specified in these instructions. Such materials should be installed in conformity with the manufacturer's specifications and/or industry standards for such materials. If masonry cladding is used, the soldier course of masonry must be one-half inch away from the bottom of the sill on all windows.

Because all construction must anticipate some water infiltration, it is important that the wall system be designed and constructed to properly manage moisture. Eagle Window & Door is not responsible for claims or damages caused by unanticipated water infiltration, deficiencies in building design, construction and maintenance, failure to install Eagle products in accordance with these instructions, or the use of Eagle products in systems which do not allow for proper management of moisture within the wall system. The determination of the suitability of all building components, including the use of Eagle products, as well as the design and installation of flashing and sealing systems, are the responsibility of you, your architect, or a construction professional. Moisture problems, including unacceptable water infiltration, have been associated with barrier systems such as EIFS (also known as synthetic stucco). Eagle products should not be used in barrier EIFS systems unless Eagle's current, recommended installation procedures for installation of windows and doors into EIFS are used. Any other use of Eagle products with barrier EIFS systems will void the warranty.

Contact your sealant supplier to choose a sealant that is compatible with, and that will adhere adequately to, all building materials used in the window area. Important: Perimeter sealant must be Grade NS Class 24 per ASTM C920 and compatible with the window/door product, nail fin and the finished exterior of the building. Use of improper sealant could result in sealant failure, resulting in air and water infiltration.

Eagle makes no warranty, expressed or implied, that the methods and procedures described in these instructions are suitable for any particular purpose or installation. These instructions do not add to or modify the terms, conditions or limitations of Eagle's manufacturer's warranty.

A drip cap is required on all windows and doors. Failure to utilize and incorporate a drip cap could void the Eagle Window & Door warranty. Refer to the Eagle warranty for additional information.

"Eagle" and all other marks where denoted are trademarks of Eagle Window & Door Manufacturing, Inc.

©2010 Eagle Window & Door Manufacturing, Inc. All rights reserved.