

# Eagle® Exterior Flat Casing Assembly Instructions

These instructions are for the assembly of exterior flat casing and sill nosing to Eagle windows and doors.

Carefully follow these instructions for assembly on the job site. Installation instructions for Eagle windows and doors are available online at [EagleWindow.com](http://EagleWindow.com).

Please read the following instructions thoroughly before starting.

## PARTS INCLUDED

Sill Shims	Corner Keys
Foam End Seals	Foam Corner Seals
Head Casing Shims	
#6 x 3/4" Embossing Screws	
#6 x 3/4" Self-tapping Screws	
Casing (with nail fin and casing connectors)	

## ⚠ WARNING

**Metal fasteners and other hardware components may corrode when exposed to preservative treated and fire-retardant treated lumber. Obtain and use the appropriate metal fasteners and hardware as called out by the installation guide to fasten unit to any rough opening made from pressure treated and fire-retardant treated lumber. Failure to use the appropriate materials for the installation may cause a failure resulting in injury, property or product damage.**

## TOOLS REQUIRED

Safety Glasses	Gloves
Hammer	Miter Saw
Cordless Drill	Caulk Gun
Tape Measure	Staple Gun
#2 Phillip Head Bits	

## SUPPLIES REQUIRED

Clean Rags  
3/8" - 5/8" Staples  
Wood or Nylon Block  
High-quality Exterior-grade Sealant

## GENERAL WARNINGS AND CAUTIONS

Read and follow warnings and cautions during assembly process. Safety should always come first.

### ⚠ WARNING

Windows and doors can be heavy. Use safe lifting techniques and a reasonable number of people with enough strength to lift, carry and install window and door products to avoid injury and/or product damage.

### ⚠ WARNING

Use caution when working at elevated heights and around unit openings. Follow manufacturers' instructions for ladders and/or scaffolding. Failure to do so may result in injury or death.

### ⚠ WARNING

Do not carry or lift unit by extension jambs. Doing so may result in injury, product or property damage.

### ⚠ WARNING

Unless specifically ordered, Eagle windows and doors are not equipped with safety glass, and if broken, could fragment causing injury. Many laws and building codes require safety glass in locations adjacent to or near doors. Eagle windows are available with safety glass that may reduce the likelihood of injury when broken. Information on safety glass is available from your local Eagle dealer.

### ⚠ WARNING

Follow manufacturers' instructions for hand or power tools. Always wear safety glasses. Failure to do so may result in injury and/or product damage.

### CAUTION

Follow instructions of foam, sealant and flashing manufacturer regarding material application and compatibility with this product.

## GLASS

Tempered or laminated safety glass is not standard and must be special ordered. Check local building codes.

Leave protective film in place until after construction is finished. Leave (NFRC) performance label in place until final inspection or for homeowner's use/records.

Protective film and exterior coating are not present on all units.

### ⚠ WARNING

Suction grips will not hold if placed over seam of film to lift or move unit. Unit will fall causing damage or injury.



### CAUTION

Sealants will damage exterior coating on glass.



## FINISHING

### CAUTION

- Finish wood surfaces immediately after installation. Unfinished wood will deteriorate, discolor, and/or may bow and split.
- Do not stain or paint weather strip, vinyl, glass or hardware. Product damage may occur.

- ▶ Film is not a substitute for masking.
- ▶ Finish all hidden wood surfaces.
- ▶ Read and follow finishing product instructions and warnings on finish material.

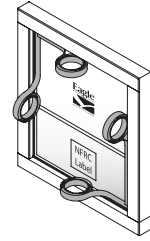

## FILM REMOVAL

Starting from a seam or corner of the film (using a plastic scraper if needed), remove the protective film from the glass surface.

Remove protective film within nine months of installation and when temperature is above 32° F.

### ⚠ WARNING

**Dispose of film immediately after removing. Film may pose suffocation hazard to children.**

### ⚠ WARNING

**Static created when removing film can ignite flammable materials or cause a shock, and can pass through the other side of the glass. See warning label on glass.**

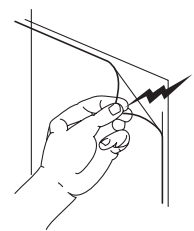

## CLEANING

Clean glass using liquid glass cleaner.

Clean exterior frame, sash, and insect screens using mild detergent and water with a soft cloth and brush.

For hard to clean areas use a nonabrasive cleaner, alcohol-and-water or ammonia-and-water.

### CAUTION

- Abrasive cleaners will damage glass surface.
- Metal razor blades can damage glass surface and exterior coating.
- Acid solutions used for cleaning masonry or concrete will damage glass, fasteners, hardware, and metal flashing. Protect unit and follow cleaning product instructions carefully. If acid contacts unit, wash all surfaces with water immediately.

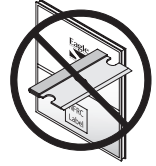

## MAINTENANCE

Do not apply any type of film to insulating glass. Thermal stress and glass damage can result. Shading devices (insulated coverings, shutters, etc.) may also cause thermal stress and condensation damage.

For more information, contact your Eagle dealer.

### ⚠ WARNING

**Do not install air conditioner in window. Injury and/or product or property damage may occur.**



## STEP 1

### Casings and installation styles.

Determine the type of flat casing to be used with your Eagle window and door products and the style of installation.

#### TYPES OF EXTERIOR FLAT CASING

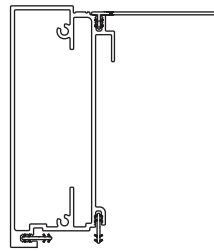

Exterior Casing  
A75B

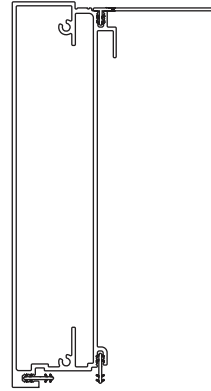

Exterior Casing  
A758

#### TYPES OF SILL NOSING

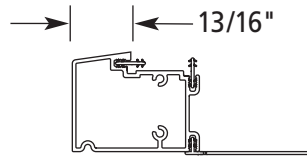

Sill Nosing - A751

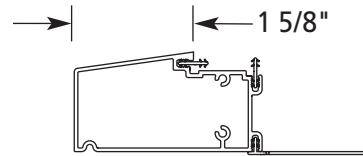

Sill Nosing - A752

#### INSTALLATION STYLES

**Note:** The icons below represent the specific styles of casing installations available (*see detail at right*).

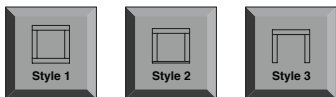

Look for these throughout the assembly steps to assist in understanding what styles of installation pertain to each step.

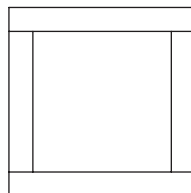

Style 1

Casings located  
on all sides

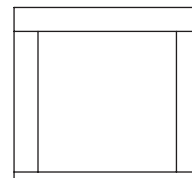

Style 2

Casings located  
on head and sides  
(sill nosing included)

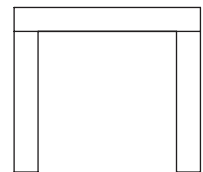

Style 3

Casings located  
on head and sides  
(sill nosing not included)

## STEP 2

### Cut head casing to length.

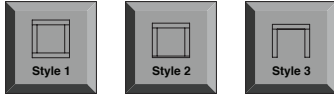

Cut the head casing to correct length with a straight cut at each end. Correct head length is determined by width of jamb casing.

3 1/2" Jamb Casing: Head Length = Frame Width + 6.150"

5 1/2" Jamb Casing: Head Length = Frame Width + 10.150"

If Installation Style 1, two pieces will be required. Otherwise one piece of head casing is required.

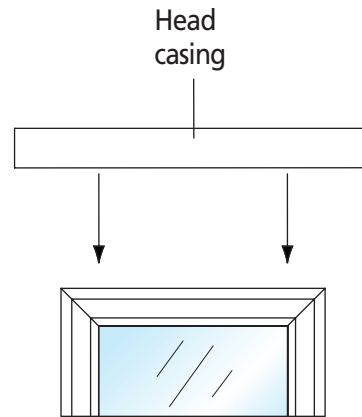

*Exterior View*

## STEP 3

### Cut sill nosing to length.



If Installation Style 1 or Style 3, skip to Step 4.

If Installation Style 2, cut sill nosing to length with a straight cut at each end. Sill nosing length is dependent on jamb casing width.

3 1/2" A75B Flat Casing Jamb: Head Length = Frame Width + 6.150"

5 1/2" A758 Flat Casing Jamb: Head Length = Frame Width + 10.150"

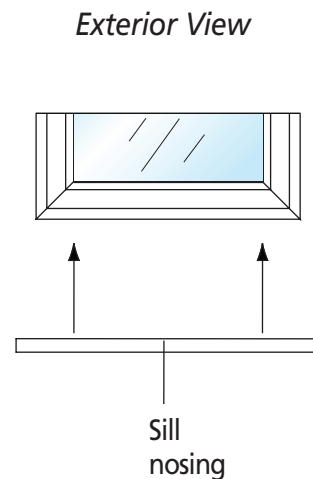

## STEP 4

### Cut jamb casing to length.

Jamb length and cut angle is dependent on style of installation.

#### Installation Style 1



Cut left and right jamb casing with a straight cut at each end.

A75B Flat casing: Jamb Length = Frame Height - .460

A758 Flat casing: Jamb Length = Frame Height - .460

#### Exterior Views

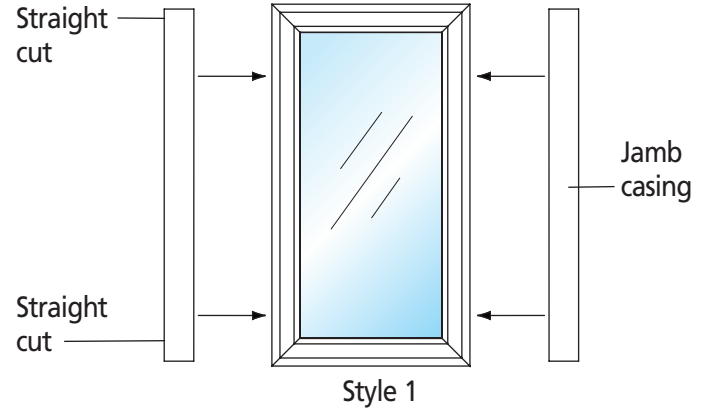

#### Installation Style 2



Cut left and right jamb casing with a straight cut at head end and a 8° bevel at sill end.

A75B Flat casing: Jamb Length = Frame Height - .460

A758 Flat casing: Jamb Length = Frame Height - .460

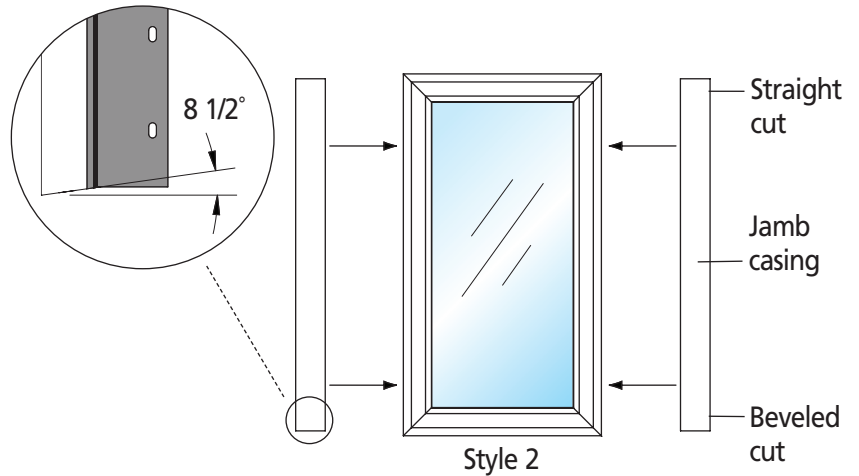

#### Installation Style 3



Cut left and right jamb casing with a straight cut at each end.

A753 Flat casing: Jamb Length = Frame Height - .460

A758 Flat casing: Jamb Length = Frame Height - .460

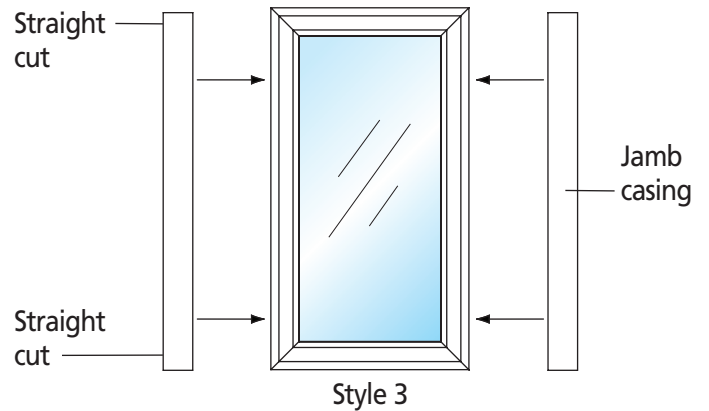

## STEP 5

### Prepare head casing for assembly.

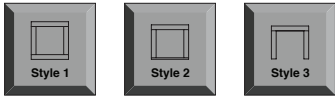

Apply head casing shims to each end of the head casing. Guide the receiver on the shim over the outside casing connector with the thin leg towards the casing. Push the shim down so that it fits inside the inside connector and is seated against the bottom of the head casing.

If Installation Style 1, prepare the casing for the sill following the same steps as the head casing.

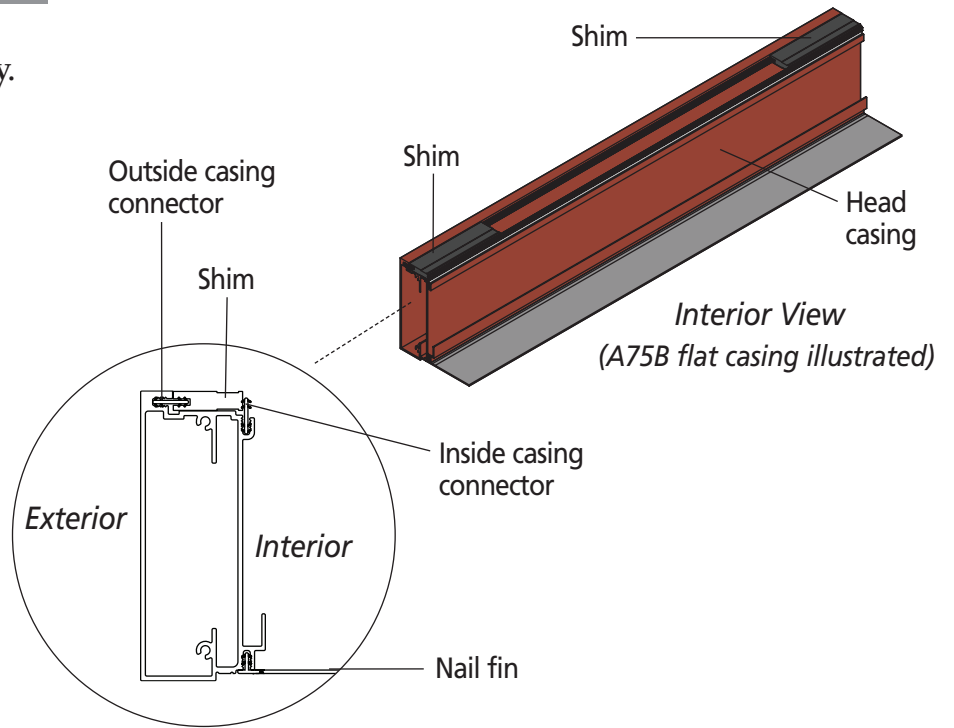

## STEP 6

### Prepare jamb casing for assembly.

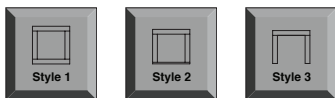

Place one foam end seal in the back cavity of each jamb casing end for a total of four seals. Keep foam end seal flush to finished edge.

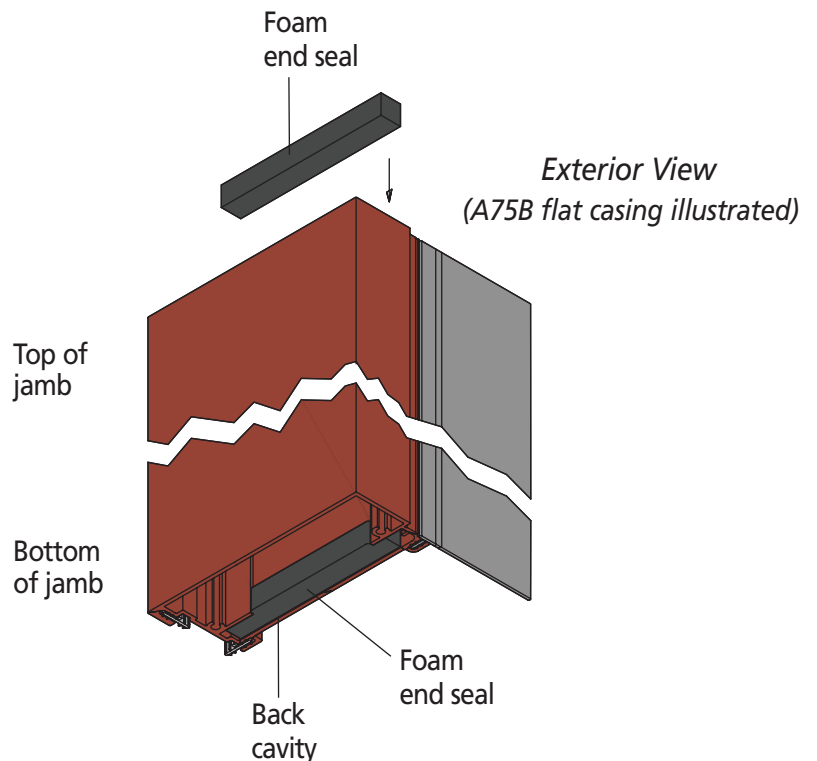

## STEP 7

Apply sealant at window corners.

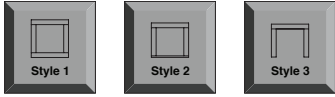

Apply 1/8" diameter bead of sealant 1/2" over and 1/2" down in the front receiver at each head corner of the unit.

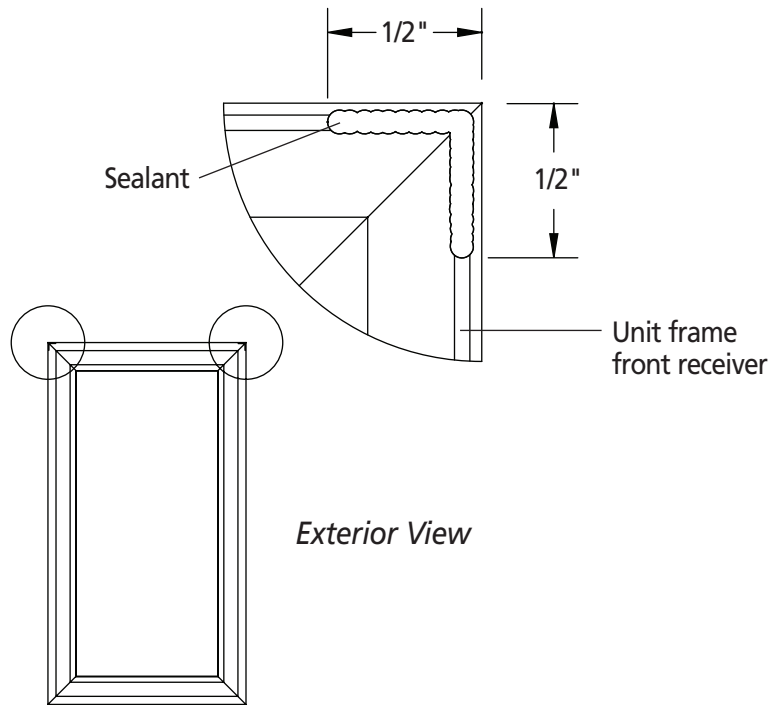

## STEP 8

Attach head casing to unit.

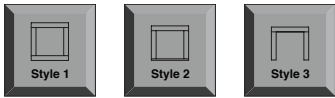

Center head casing on unit head. Rotate head casing slightly, inserting the outside casing connector in the outside receiver of the unit head. Push casing down towards unit and rotate upward to seat the inside casing connector into the nail fin receiver on the unit head.

Use a hammer and wood or nylon block to seat the head casing if required.

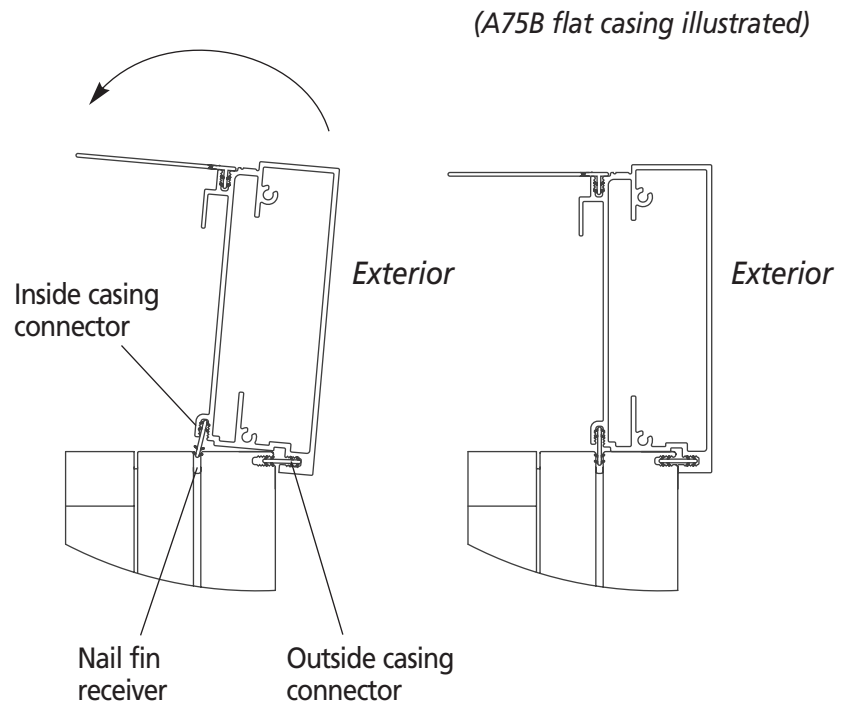

## STEP 9

### Attach sill nosing to unit.



If Installation Style 1 or 3, skip to Step 13.

Center sill nosing on unit sill.  
Rotate sill nosing slightly, inserting the outside casing connector in the outside receiver of the sill. Push sill nosing down towards unit and rotate back up to seat the inside casing connector into the nail fin receiver on the unit. Use a hammer and wood or nylon block to seat sill nosing if required.

(A751 sill nosing illustrated)

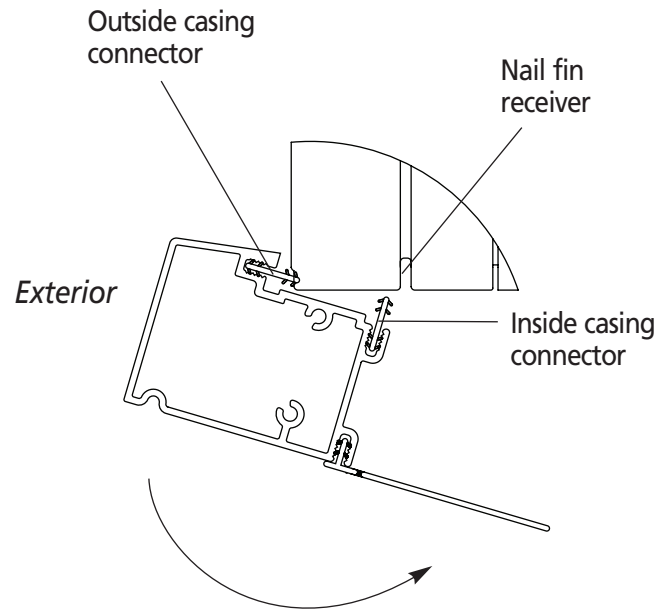

## STEP 10

### Seal sill nosing to unit.



Apply a 1/4" diameter bead of sealant along the outside edge of the inside casing connector of the sill nosing. Run bead to the unit edge and then out to the front receiver of window as shown. Then run a bead 3" up the side of the unit on the outside edge of the nail fin receiver. Repeat step on other side.

Exterior View  
(A751 sill nosing illustrated)

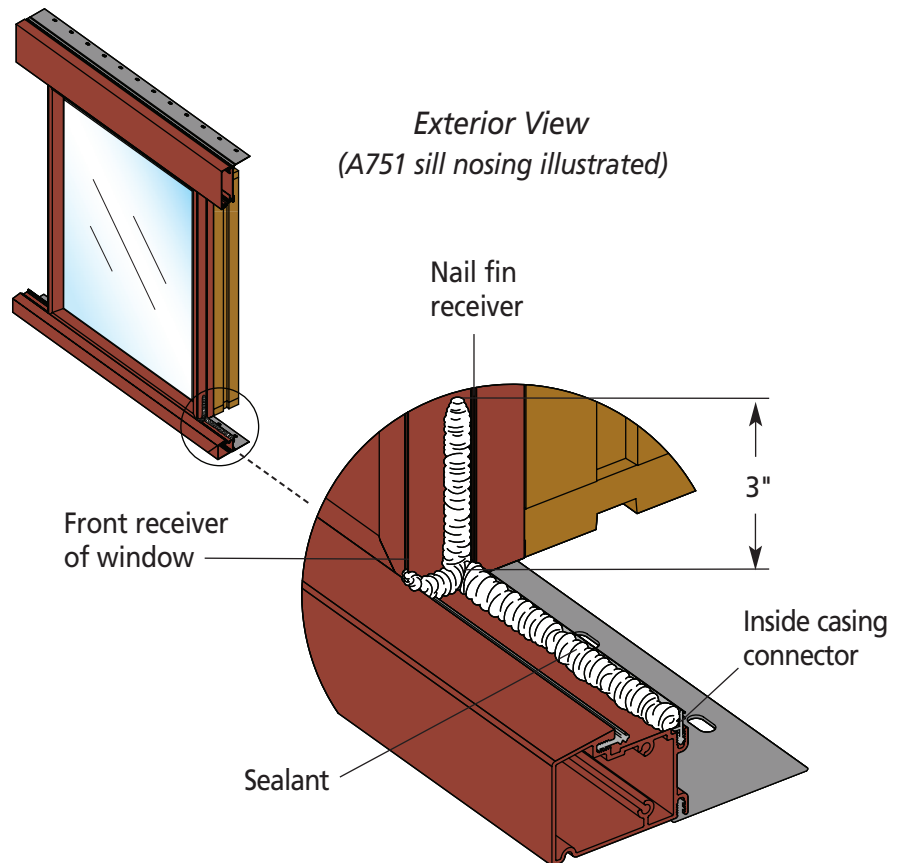

## STEP 11

Attach sill shims to sill nosing.



Position sill shim with the thin nose pointed towards the exterior and the kerf at the bottom. Align the front kerf of shim to the outside casing connector. Push shim into the connector and then down to fit over inside casing connector. Repeat for other side of sill.

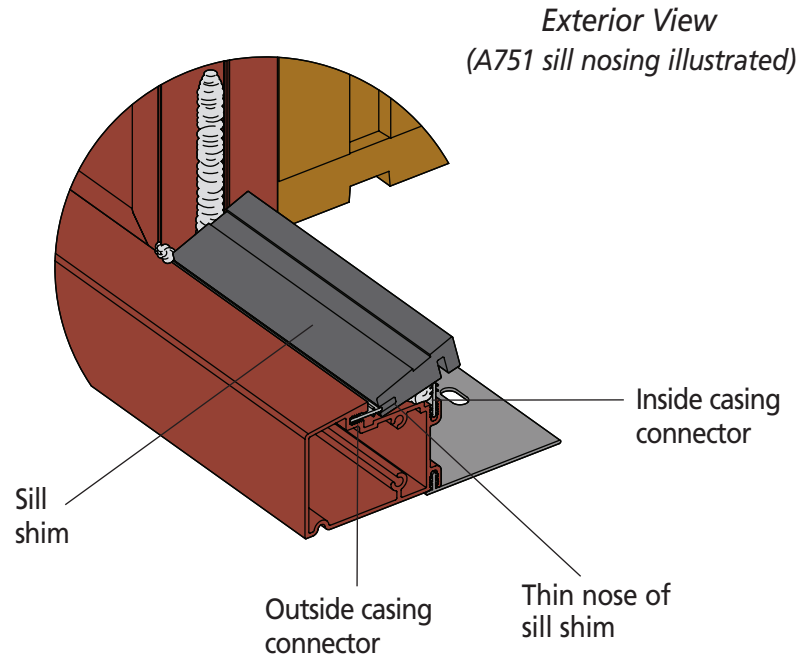

## STEP 12

Apply sealant to shims on sill nosing.



Apply a 1/4" bead of sealant to the top of the sill shim from the unit to the end of the sill shim.

Repeat on other side.

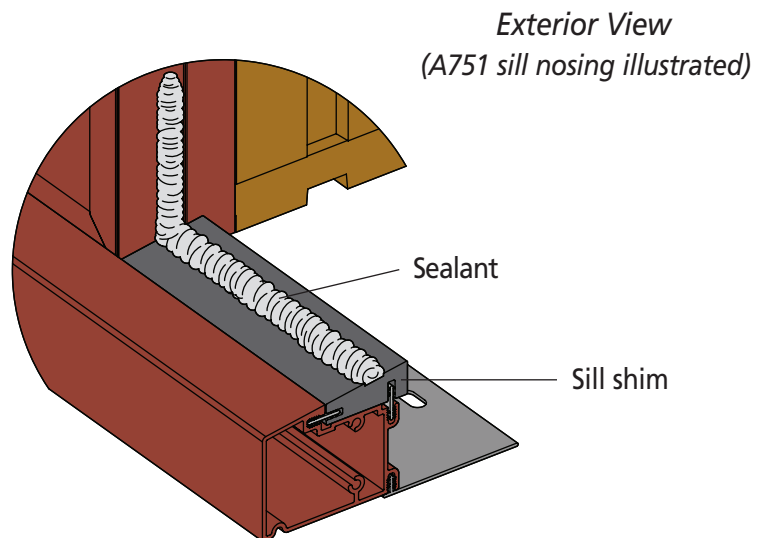

## STEP 13

Apply sealant to shims on head casing.

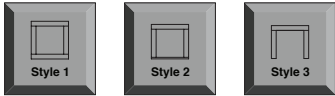

Apply a 3/8" diameter bead of sealant to the recessed area of the head casing shim. Sealant should start at the unit and run out to the end of the shim in a L-shaped pattern as shown.

*Note: If Installation Style 1, repeat steps for sill casing.*

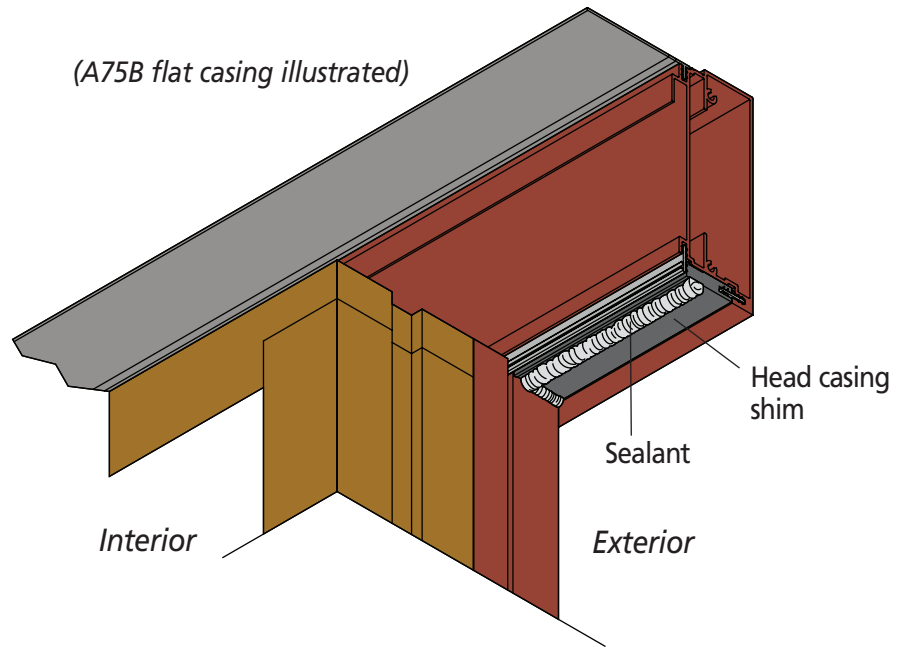

## STEP 14

Attach jamb casing to unit.



Take the appropriate side jamb casing and align the outside casing connector with the outside receiver of the unit, tight to head casing.

Press the casing down to fully seat outside connector. Rotate back of casing down and snap inside casing connector into nail fin receiver (see Fig. A).

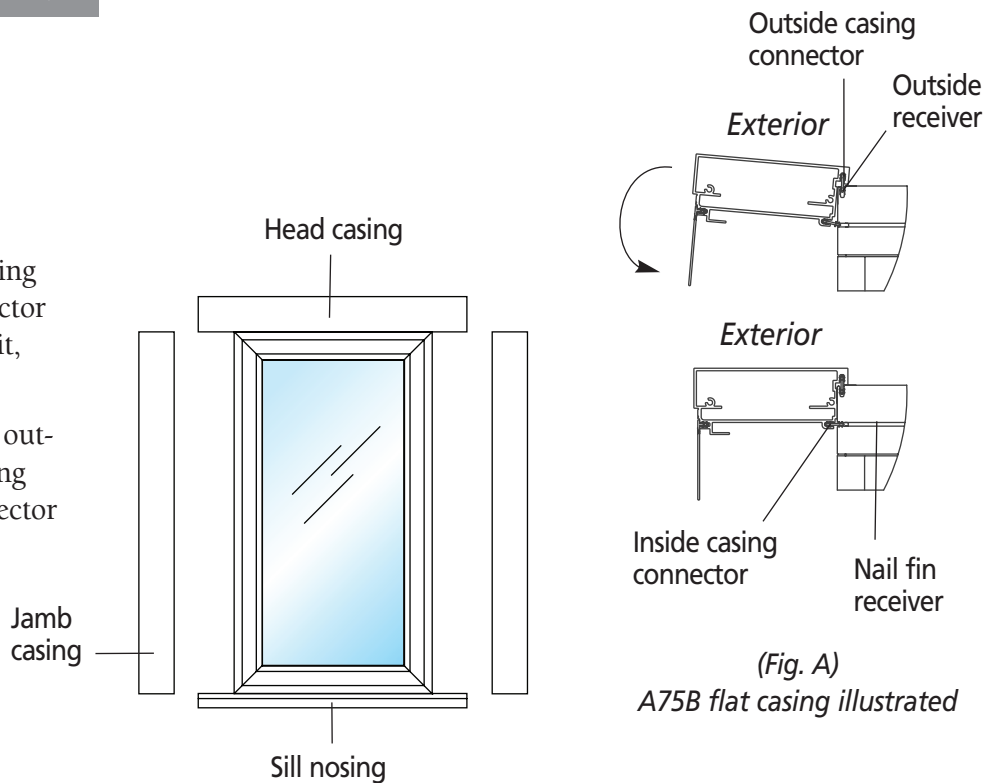

(Fig. A)  
A75B flat casing illustrated

Exterior View  
(Installation Style 2 illustrated)

## STEP 15

Fully seat the casing to unit.

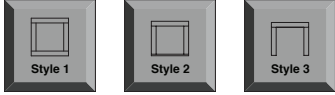

Place a wood or nylon block at the edge of the casing and tap lightly with a hammer to fully seat casing.

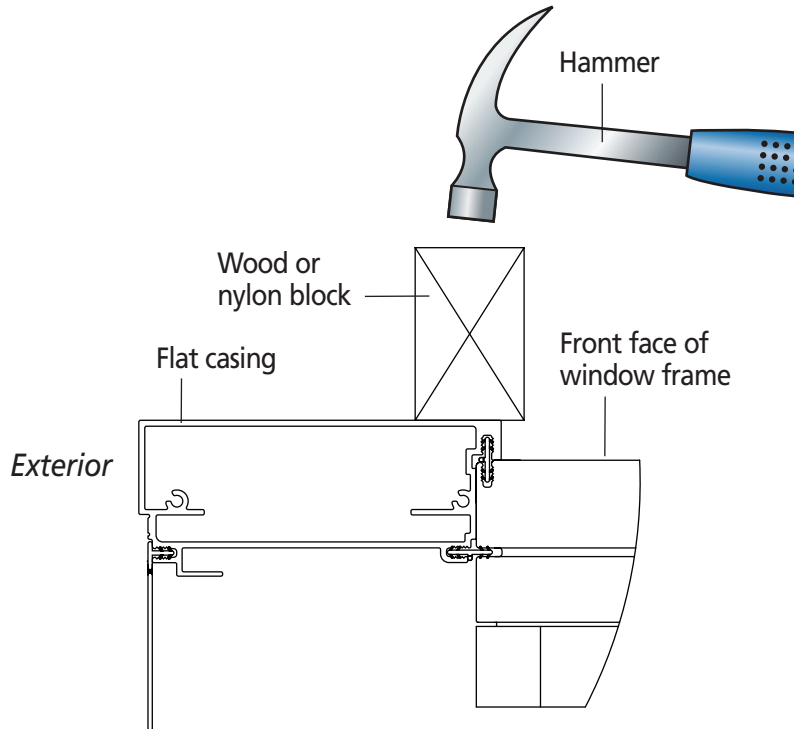

(A75B flat casing illustrated)

## STEP 16

Attach sill nosing end caps.



If Installation Style 1 or 3, skip to Step 17.

Apply a 1/8" diameter bead of sealant around the edge of the sill nosing extrusion leaving a gap for drainage, as shown.

Align the end cap with the sill nosing extrusion. Use two #6 x 3/4" embossing screws to attach the end cap to the sill nosing.

Use a #6 x 3/4" self-tapping screw to screw the end cap to the jamb casing.

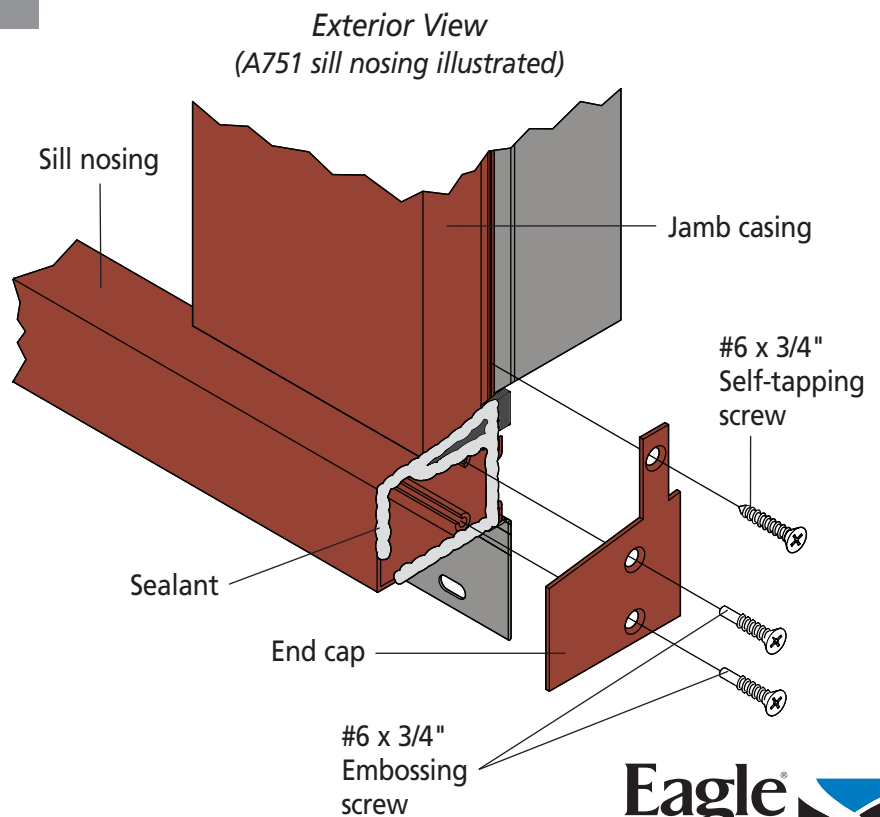

## STEP 17

### Attach flat casing end caps.

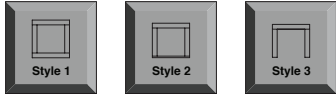

Apply a 1/8" diameter bead of sealant around the edge of the head flat casing extrusion as shown.

Align the end cap with the head casing extrusion. Use two #6 x 3/4" embossing screws to attach the end cap to the head casing.

Use a #6 x 3/4" self-tapping screw to screw the end cap to the jamb casing.

If Installation Style 1, repeat at sill.

Assembly is now complete for Installation Styles 1, 2 and 3.

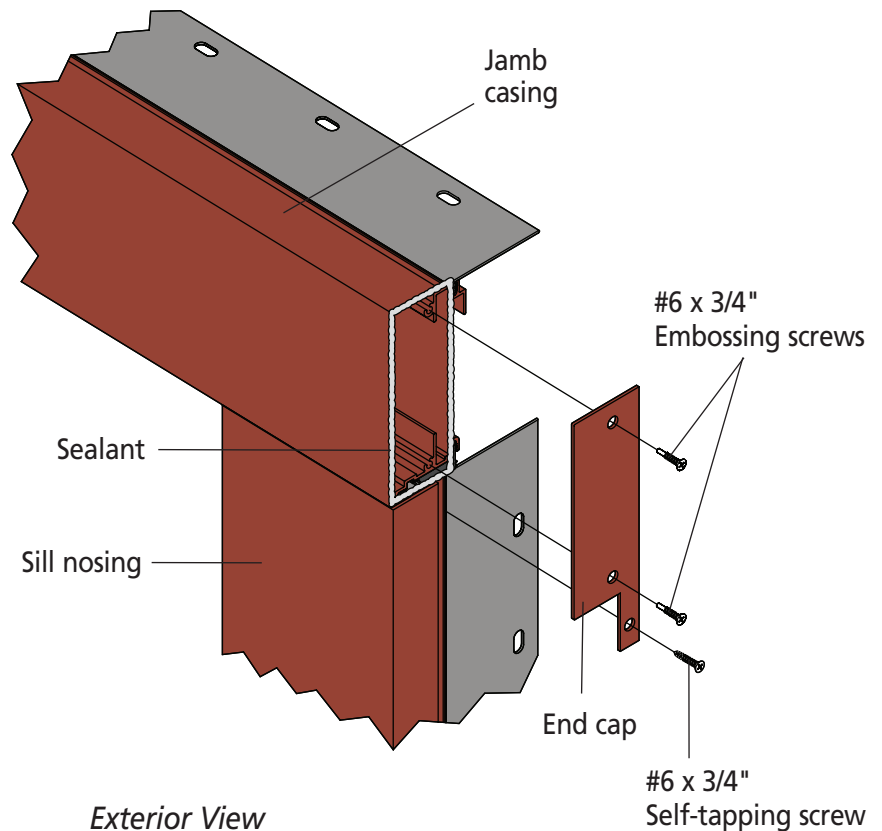

## PRODUCT INSTALLATION DETAILS

For product installation information, please refer to the installation instructions at [EagleWindow.com](http://EagleWindow.com)



## SECTION DETAIL - BRICK EXTERIOR APPLICATION

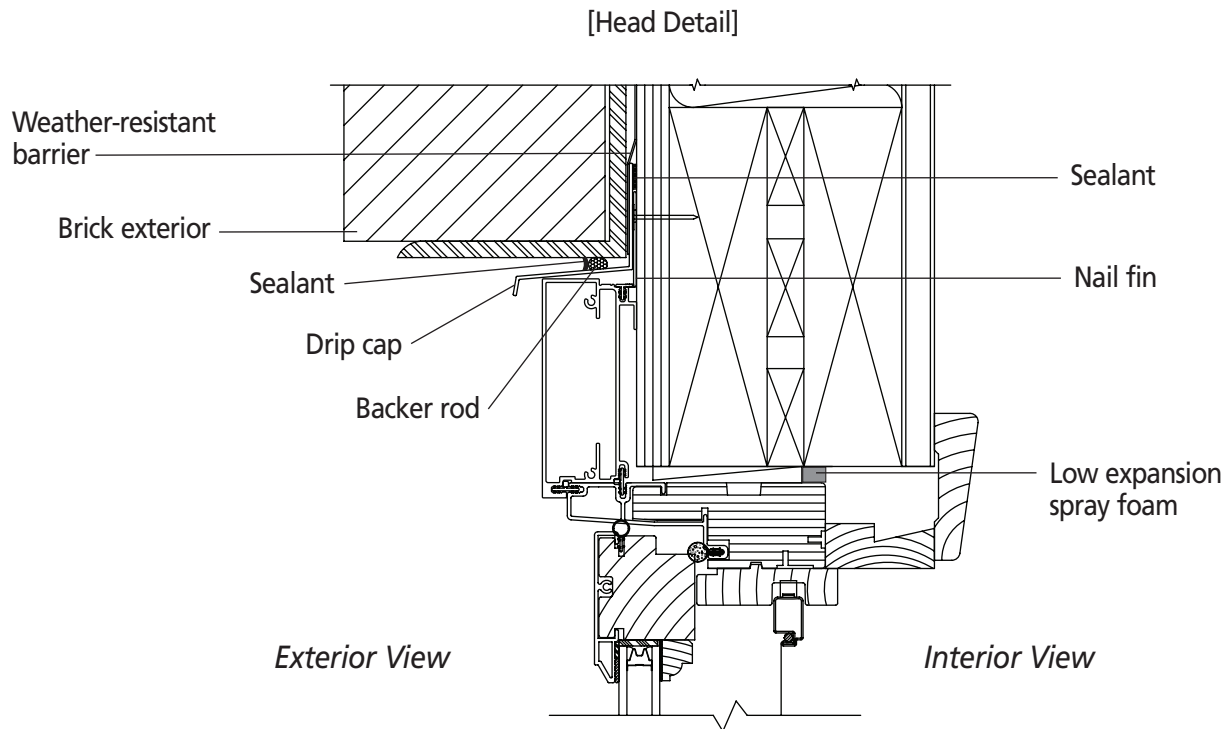

## SECTION DETAIL - WOOD SIDING AND TRIM APPLICATION

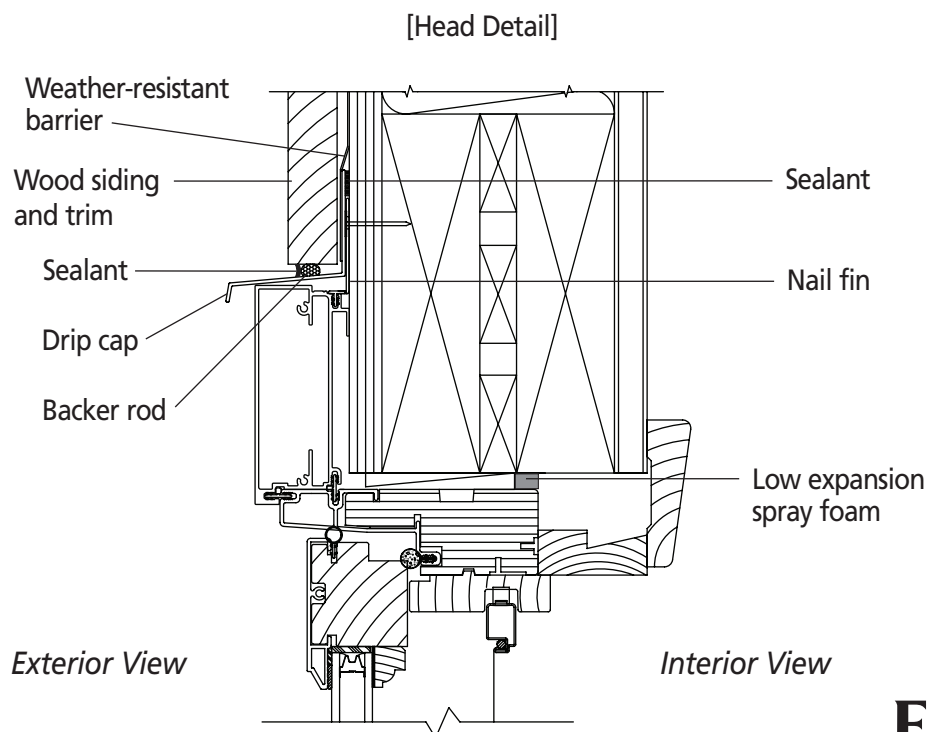

## NOTES

### See the Caring for Eagle Windows and Doors guide for additional care and maintenance information.

Methods and procedures for installation of siding and other cladding materials, trim, moldings and other finish materials around window openings are not specified in these instructions. Such materials should be installed in conformity with the manufacturer's specifications and/or industry standards for such materials. If masonry cladding is used, the soldier course of masonry must be one-half inch away from the bottom of the sill on all windows.

Because all construction must anticipate some water infiltration, it is important that the wall system be designed and constructed to properly manage moisture. Eagle Window & Door is not responsible for claims or damages caused by unanticipated water infiltration, deficiencies in building design, construction and maintenance, failure to install Eagle® products in accordance with these instructions, or the use of Eagle products in systems which do not allow for proper management of moisture within the wall system. The determination of the suitability of all building components, including the use of Eagle products, as well as the design and installation of flashing and sealing systems, are the responsibility of you, your architect, or a construction professional. Moisture problems, including unacceptable water infiltration, have been associated with barrier systems such as EIFS (also known as synthetic stucco). Eagle products should not be used in barrier EIFS systems unless Eagle's current, recommended installation procedures for installation of windows and doors into EIFS are used. Any other use of Eagle products with barrier EIFS systems will void the warranty.

Contact your sealant supplier to choose a sealant that is compatible with, and that will adhere adequately to, all building materials used in the window area. Important: Perimeter sealant must be Grade NS Class 24 per ASTM C920 and compatible with the window/door product, nail fin and the finished exterior of the building. Use of improper sealant could result in sealant failure, resulting in air and water infiltration.

Eagle makes no warranty, expressed or implied, that the methods and procedures described in these instructions are suitable for any particular purpose or installation. These instructions do not add to or modify the terms, conditions or limitations of Eagle's manufacturer's warranty.

A drip cap is required on all windows and doors. Failure to utilize and incorporate a drip cap could void the Eagle Window & Door warranty. Refer to the Eagle warranty for additional information.

“Eagle” and all other marks where denoted are trademarks of Eagle Window & Door Manufacturing, Inc.

©2010 Eagle Window & Door Manufacturing, Inc. All rights reserved.