



Installation Guide

for Wood Outswing Eagle Entranceways
and Extended Half Circle Doors

INSTALLER: Please leave this guide with the building owner to file for future reference.

Congratulations! You have just purchased one of the many fine Eagle® products. Proper assembly, installation and maintenance are essential if the benefits of your Eagle product are to be fully attained. Therefore, please read and follow this instruction guide completely. If your abilities do not match this procedure's requirements, contact an experienced contractor. You may direct any questions about this or other products to your local Eagle Window & Door dealer. For the dealer nearest you, visit our dealer locator at EagleWindow.com or call 1-800-324-5354. Thank you for choosing Eagle.

Important Safety, Assembly, and Installation Information

Every assembly and installation is different (windloads, structural support, etc.). Eagle strongly recommends consultation with an Eagle dealer or an experienced contractor, architect, or structural engineer prior to the assembly and installation of any Eagle product. Eagle has no responsibility in regard to the post-manufactured assembly and installation of Eagle products.

⚠ WARNING

Use caution when working at elevated heights and around unit openings. Follow manufacturer's instructions for ladders and/or scaffolding. Failure to do so may result in injury or death.

⚠ WARNING

Follow manufacturer's instructions for hand or power tools. Always wear safety glasses. Failure to do so may result in injury and/or product damage.

⚠ WARNING

Windows and doors can be heavy. Use safe lifting techniques and a reasonable number of people with enough strength to lift, carry and install window and door products to avoid injury and/or product damage.

⚠ WARNING

Unless specifically ordered, Eagle windows and doors are not equipped with safety glass, and if broken, could fragment causing injury. Many laws and building codes require safety glass in locations adjacent to or near doors. Eagle windows and doors are available with safety glass that may reduce the likelihood of injury when broken. Information on safety glass is available from your local Eagle dealer.

⚠ CAUTION

- Factory supplied exterior brickmold and casings **DO NOT** take the place of standard window and door flashing. Unit must be properly flashed and sealed with silicone for protection against water and air infiltration. Use non-reflective flashings.
- Do not apply any type of film to glass. Thermal stress conditions resulting in glass damage could occur.
- Use of movable insulating materials such as window coverings, shutters, and other shading devices may damage glass. In addition, excessive condensation may result causing deterioration of windows and doors.

⚠ WARNING

Unsecured doors may swing open or closed causing injury. Secure door when open.



⚠ WARNING

DO NOT carry door unit horizontally, exterior side down. Door panels may swing open causing product damage and/or injury.

⚠ WARNING

Metal fasteners and other hardware components may corrode when exposed to preservative treated and fire-retardant treated lumber. Obtain and use the appropriate metal fasteners and hardware as called out by the installation guide to fasten unit to any rough opening made from pressure treated and fire-retardant treated lumber. Failure to use the appropriate materials for the installation may cause a failure resulting in injury, property or product damage.

Parts Included

- (1) Installation Guide
- (1) Care, Finish & Maintenance Guide
- (1) Door Unit
- (2) #10 x 2-1/2" Hinge Screws
- (1) Multi-Point Lock Set (optional)

Tools and Supplies

- Safety Glasses
- Tape Measure
- 4' Level
- Phillips Screwdriver
- Caulk Gun
- Sealant
- Hammer
- Shims
- Putty Knife
- Pry Bar
- Fasteners (Stainless Steel, if required)
 - 3" Galvanized Finish Nails
 - #10 x 1-1/2" Screws

1. Unit Preparation

⚠ WARNING

Door panels must be secured in closed position until unit is installed. **DO NOT** remove Steel Locking Brackets until unit is secured in opening. Failure to do so may result in door panel inadvertently opening causing injury, property and/or product damage.

CAUTION

Gussets keep door unit square until installed. **DO NOT** remove Gussets until unit is secured in opening. Failure to do so may result in property, and/or product damage.

- Remove unit from packaging being careful not to damage unit. Place unit exterior side up on support boards over a clean, flat work surface.
- Remove loose items such as brickmold, interior trim, and drip cap. Extension jambs are factory applied unless ordered loose.
- Remove shipping braces using a pry bar being careful not to damage unit. Do not remove *Gussets* or *Steel Locking Brackets* (if present) until unit is secured in rough opening in **Step 7**.

Steel Locking Brackets



Exterior View

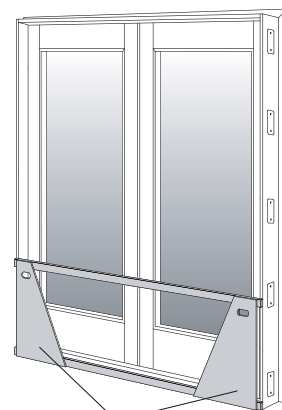

Gussets

Interior View

2. Prepare Rough Opening

- Width of rough opening should be 3/4" more than unit width. Height of rough opening should be 1/2" more than unit height.
- Check sill plate for level. Sill **must** be level. Shim if needed.
- Check rough opening for plumb and level. If rough opening is **not** plumb or level, correct as needed.
- Check rough opening for square by measuring diagonally across, upper left to lower right and upper right to lower left corner. If measurements are within 1/8", opening is square. If rough opening is **not** square, correct as needed.

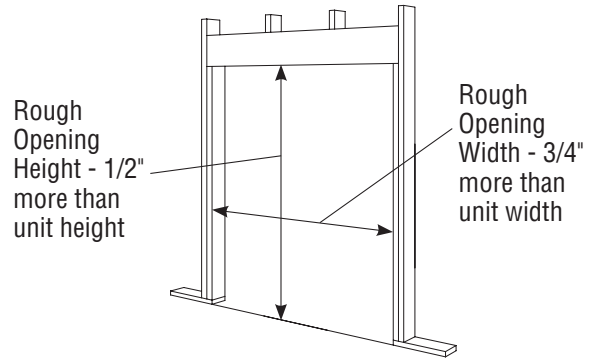

Interior View

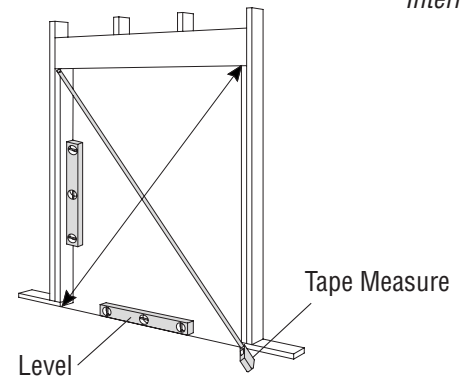

Interior View

CAUTION

DO NOT install unit directly on masonry/concrete surface. Place full length barrier (i.e. treated wood, tar paper, ice/water membrane) between unit sill and masonry/concrete surface. Failure to use barrier and to seal barrier to unit sill and masonry/concrete surface may result in product and/or property damage. Entire barrier must be sealed to masonry/concrete surface to help prevent water infiltration. Barrier thickness must not exceed 1/4".

3. Seal Rough Opening

CAUTION

Sealant must be compatible with all materials it contacts. Follow sealant manufacturer's instructions regarding surface cleaning and preparation, compatibility, application, and temperature when applying sealant. Failure to do so may result in water infiltration.

- Apply three, continuous 3/8" beads of sealant to bottom of rough opening full length and 2" up each side. Space beads evenly across width of the rough opening.
- For units supplied with brickmold, apply a continuous 3/8" bead of sealant, full perimeter, around rough opening 1/2" from edge.

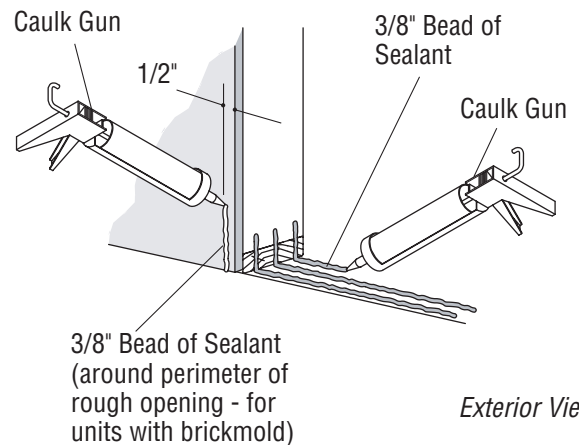

Exterior View

4. Position Installation Clips

- Rotate *Installation Clips* 90° into position around frame, as shown, before placing unit into rough opening.
- For extended half circle and arch top units, relocate *Installation Clips* on radius head jamb for securing to building framing as needed.

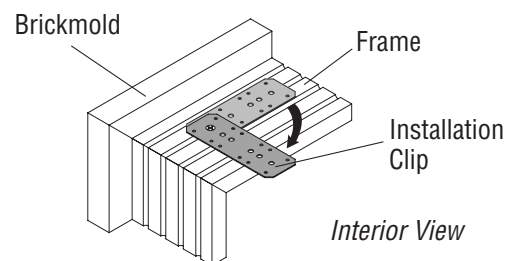

Interior View

5. Install Unit

⚠ WARNING

Windows and doors can be heavy. Use safe lifting techniques and a reasonable number of people with enough strength to lift, carry and install window and door products to avoid injury and/or product damage.

⚠ WARNING

Door panels must be kept secured in closed position. Unsecured door panels may swing open causing injury.

⚠ WARNING

Support unit in rough opening at all times until secure. Failure to support unit could result in unit falling causing injury, property, and/or product damage.

- Lift and center unit in rough opening, setting sill of unit onto sealant, from the exterior.
- Push top in until brickmold is firmly pressed into sealant around perimeter of rough opening. Brickmold must be flush with exterior of opening.

CAUTION

A minimum space of 1/4" is required around exterior perimeter of unit between unit and building framing. Failure to properly space product in opening may result in product and/or property damage.

- Adjust door unit in opening from the interior. Unit must be plumb, level, and square. Spaces on both sides, between unit and the rough opening, must be equal.
- Check unit for square by measuring diagonally, upper left to lower right and upper right to lower left corners. Both measurements must be equal. Correct as needed.
- Insert shims between rough opening and door unit, directly behind *Hinges* and beside each *Installation Clip* from the interior. Shims are installed between jambs and building framing to prevent jambs from bowing.
- Recheck plumb, level, and square of unit. Adjust shims as needed.

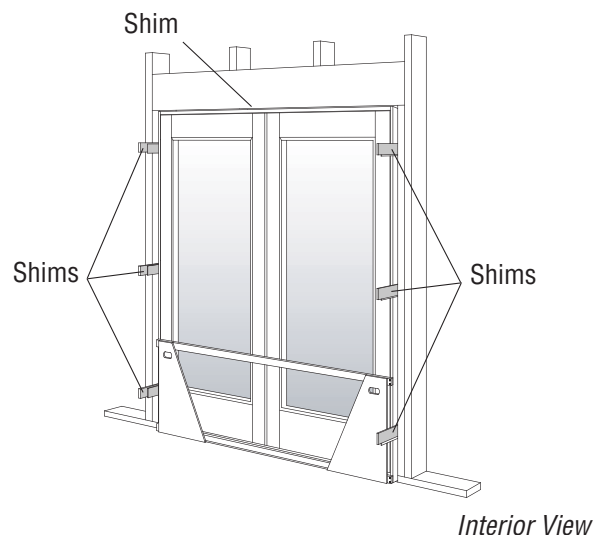
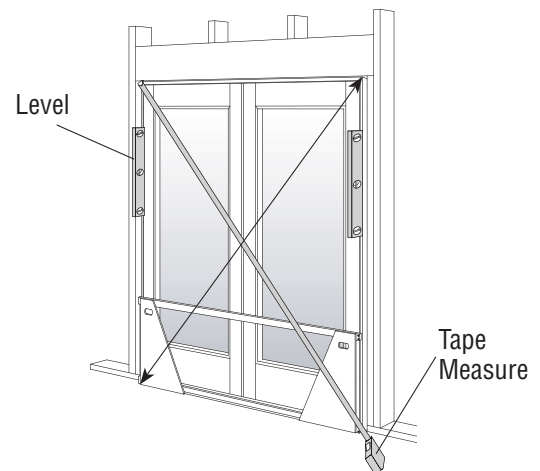
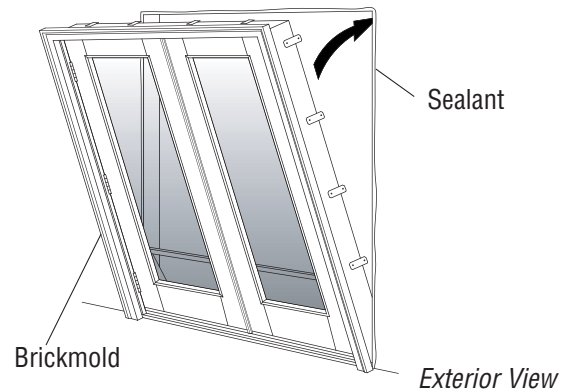

6. Secure Unit In Opening

⚠ WARNING

Metal fasteners and other hardware components may corrode when exposed to preservative treated and fire-retardant treated lumber. Obtain and use the appropriate metal fasteners and hardware as called out by the installation guide to fasten unit to any rough opening made from pressure treated and fire-retardant treated lumber. Failure to use the appropriate materials for the installation may cause a failure resulting in injury, property or product damage.

NOTICE

Both Installation Clips and nailing through brickmold are recommended for installing all units. If both cannot be used, unit must be secured to building structure through frame.

- Bend and fasten *Installation Clips* to framing using #10 x 1-1/2" screws.
- Tack nail through brickmold directly into framing, 6" from top and bottom of each side, using 3" finish nails.

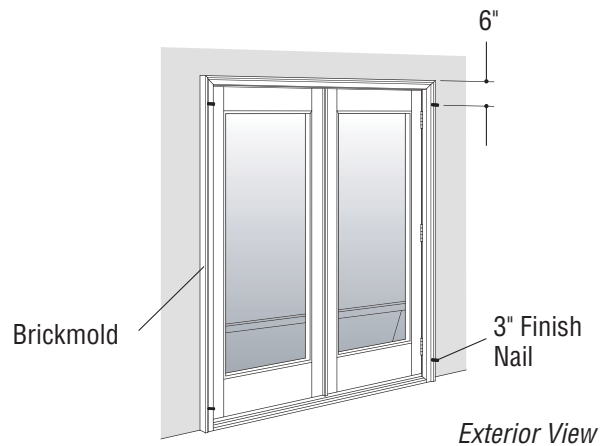
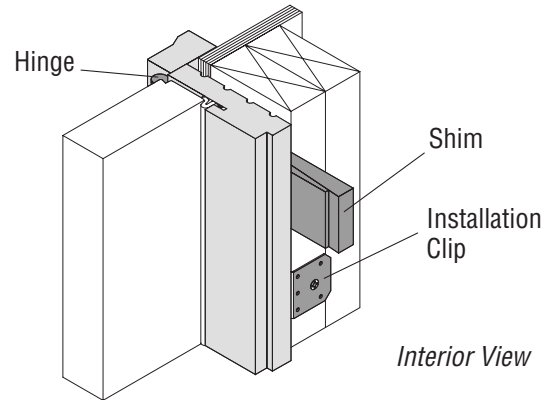

7. Remove Gussets and Brackets

CAUTION

Some units may have more than one Steel Locking Bracket. Remove all Steel Locking Brackets from frame before opening door(s). Failure to do so may result in product damage.

- Remove *Gussets* and *Steel Locking Brackets* from door frame using a Phillips screwdriver.
- Open door panel(s) and remove *Steel Locking Brackets* from door panels using a Phillips screwdriver.

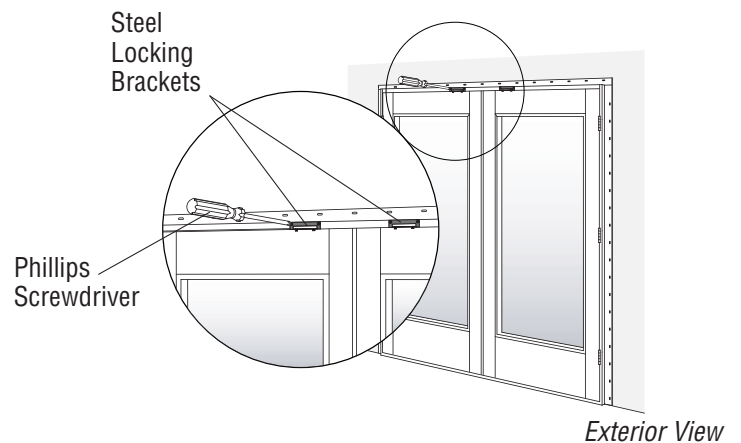
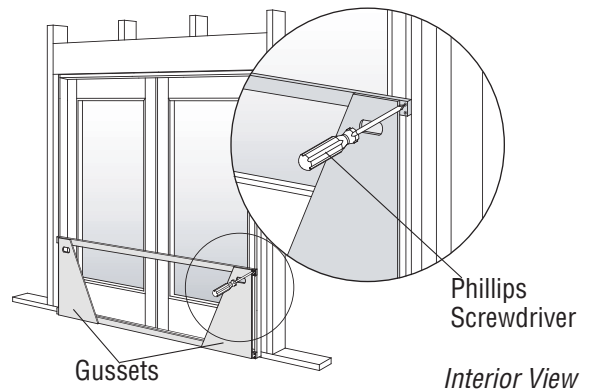

8. Check Clearance and Operation

⚠ WARNING

Metal fasteners and other hardware components may corrode when exposed to preservative treated and fire-retardant treated lumber. Obtain and use the appropriate metal fasteners and hardware as called out by the installation guide to fasten unit to any rough opening made from pressure treated and fire-retardant treated lumber. Failure to use the appropriate materials for the installation may cause a failure resulting in injury, property or product damage.

- Fasten *Hinges* using #10 x 2-1/2" *Hinge Screws* where labeled on *Hinges*. (Not required on fixed units or units with sidelights.)
- Determine if clearance and operation are correct. If clearance and/or operation are not correct, loosen screws in *Installation Clips*, remove nails from brickmold, and adjust shims between door frame and rough opening as needed. Tighten screws in *Installation Clips* and reapply brickmold.
- Check clearance and operation again. If correct, nail brickmold every 12" using 3" finish nails.

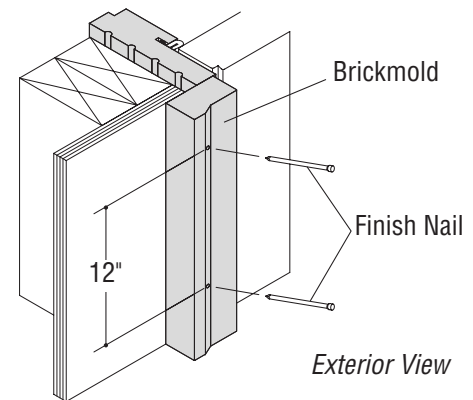
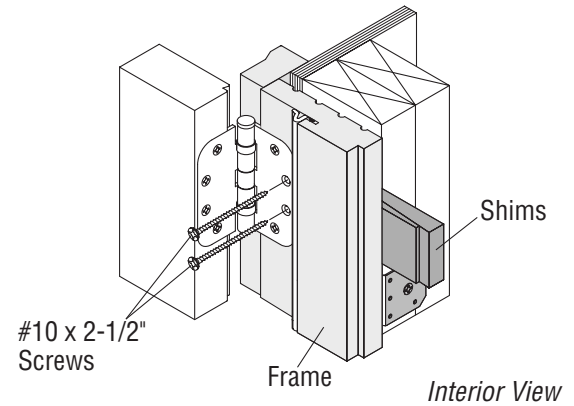

Securing Through Frame

- If securing through frame, (where not using *Installation Clips* or nailing through brickmold) predrill 3/16" holes through unit frame 4" from each corner and every 16" between.
- Insert shims between frame and rough opening behind 3/16" holes.
- Fasten through predrilled holes using #10 x 2-1/2" screws.
- Recheck plumb, level, and square of unit. Adjust shims as needed.

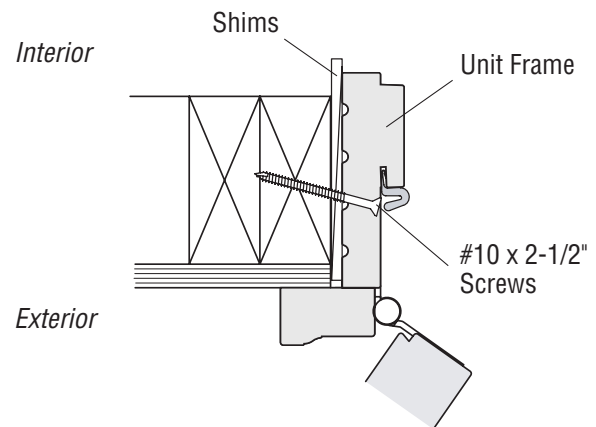

9. Hardware Installation

- For factory supplied *Multi-Point Hardware*, install hardware as directed in supplied instructions.
- For hardware supplied by others, follow hardware manufacturer's instructions.

NOTICE

For all doors over 6' 8" high, Multi-Point Hardware is recommended.

10. Insulate Around Unit

CAUTION

When insulating between unit frame and rough opening, or between units when joining, **DO NOT** overpack batt insulation or overfill with expandable foam. Bowed jambs will result affecting product performance and/or causing improper unit operation.

- Insulate between frame and rough opening from the interior side of the door. **DO NOT** overpack batt insulation or overfill with expandable foam.

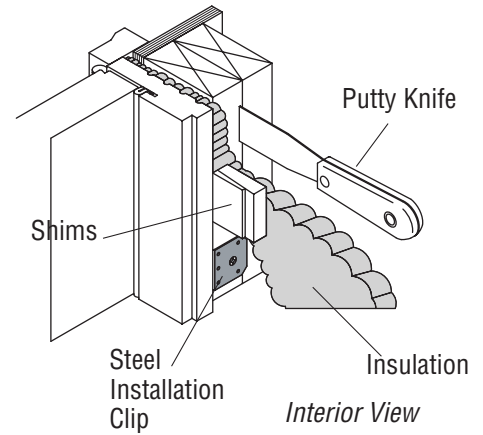

11. Apply Exterior Finish and Seal

NOTICE

Use foam backer rod to seal and reduce the depth of gap before filling with sealant, as needed. Follow sealant manufacturer's instructions.

- Apply exterior finish leaving 1/4" space between brickmold or frame and exterior finish.
- Apply a continuous bead of sealant around exterior perimeter of door unit between brickmold or frame and exterior finish, filling the 1/4" space.

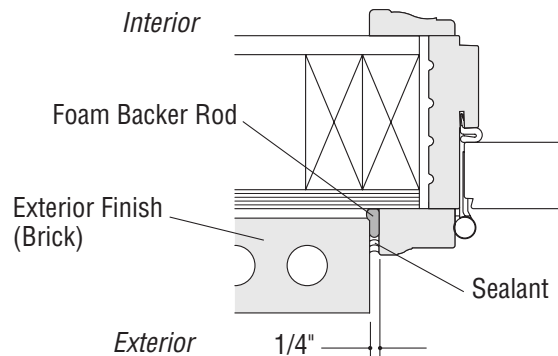
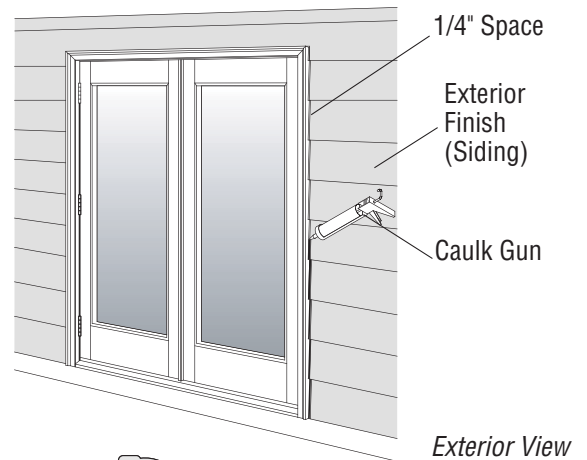

Outswing Frame Limitations

CAUTION

- Install door stop(s), or another form of limiting device, to prevent door panel from striking brickmold or adjacent exterior wall finish when opening. Failure to do so may result in product and/or property damage.
- All extended half circle and extended gothic outswing doors **must be** restricted to opening 90° immediately after installation. Failure to do so may result in product and/or property damage.

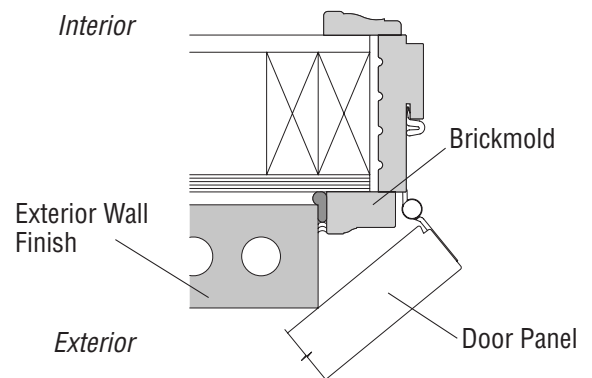

Finishing, Cleaning, and Maintenance Instructions

CAUTION

- **DO NOT** expose unfinished wood to high moisture conditions, excessive heat or humidity. Finish wood surfaces immediately after installation. Unfinished wood surfaces will discolor, deteriorate, and/or may bow and split.
- **DO NOT** stain or paint weather strip, silicone beads, vinyl, glass, or hardware.
- Acid solutions used to wash masonry/concrete will damage glass, fasteners, hardware, and metal flashing. Follow the acid solution manufacturer's instructions carefully. Protect and/or cover Eagle® products during the cleaning process to prevent acid contact. If acid does come in contact with unit, immediately wash all surfaces with clean water.

FINISHING

Read and follow finishing manufacturer's instructions and warnings on each container of finishing material for priming, painting, staining, and varnishing.

CLEANING

Clean all non-wood surfaces with a mild detergent-and-water solution and a soft cloth or brush. **DO NOT** use abrasive cleaners or solutions containing corrosive solvents.

MAINTENANCE

Immediately sand and refinish any wood that becomes stained or mildewed to prevent further discoloration and/or damage. For further information, contact your local Eagle Dealer. Visit our dealer locator at EagleWindow.com for the dealer nearest you.

Adjustment Tip

NOTICE

Two shims (1/16" & 1/32" thick), located behind each Hinge, can be removed or added to adjust door panel clearance within the frame. They are used to adjust door panel(s) after installed and trimmed.

- Open door panel 90°.
- Loosen hinge screws on side of *Hinge* attached to door panel.
- Remove or add shims as needed, behind *Hinge*, from the exterior.
- Retighten hinge screws.
- Close door. Check operation of the door and the clearance between door panel and frame. If door panel is still out of alignment, repeat as needed.

Remove Shim From This Hinge

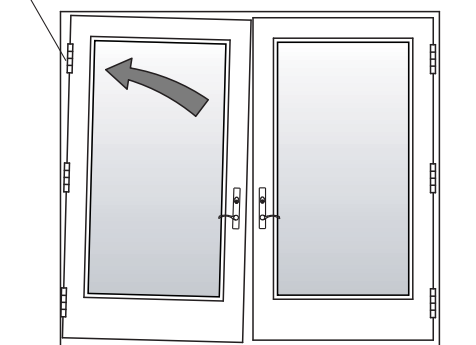

Exterior View

