



# Eagle mechanically fastened clad window installation instructions

These instructions are for typical installation in new typical **wood frame wall construction**. These instructions and methods are not intended for use in other construction types or for replacement installations. These instructions and methods may not be appropriate for a specific installation due to design of the building, construction methods used, building conditions or site conditions, any of which may require different methods or procedures. You and your architect or installing contractor are responsible for determining the method and procedures appropriate to your specific installation.

*These alternate instructions are suitable for the installation of Eagle clad wood windows using mechanically fastened flashing installed prior to the application of the weather-resistant barrier. Standard installation instructions are available at <http://www.EagleWindow.com>*

## STEP 1

Be sure you have all tools required:



Tape measure



Square



Utility knife or scissors



Level



Hammer

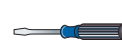

Flat-blade screwdriver



Stapler

## STEP 2

Be sure you have a sufficient supply of all materials required:

Take care to anticipate all material needs before beginning work. Additional materials may be needed in any particular installation.



Shims or spacers made of cedar or other impervious material



9" Moistop® neXT Flashing

For more information, visit: [www.fortifiber.com](http://www.fortifiber.com)

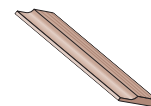

Interior trim and/or jamb extensions (15' to 40' per window)

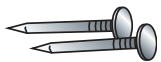

2" galvanized roofing nails (1/4 pound per window)

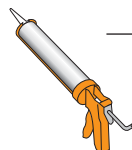

High quality exterior grade silicone sealant



Closed-cell foam backer rod or sealant backer (12' to 30' per window)



Great Stuff Pro™ Window & Door Insulating Foam Sealant

For more information, visit: [www.dow.com](http://www.dow.com)

## Window installation diagram:

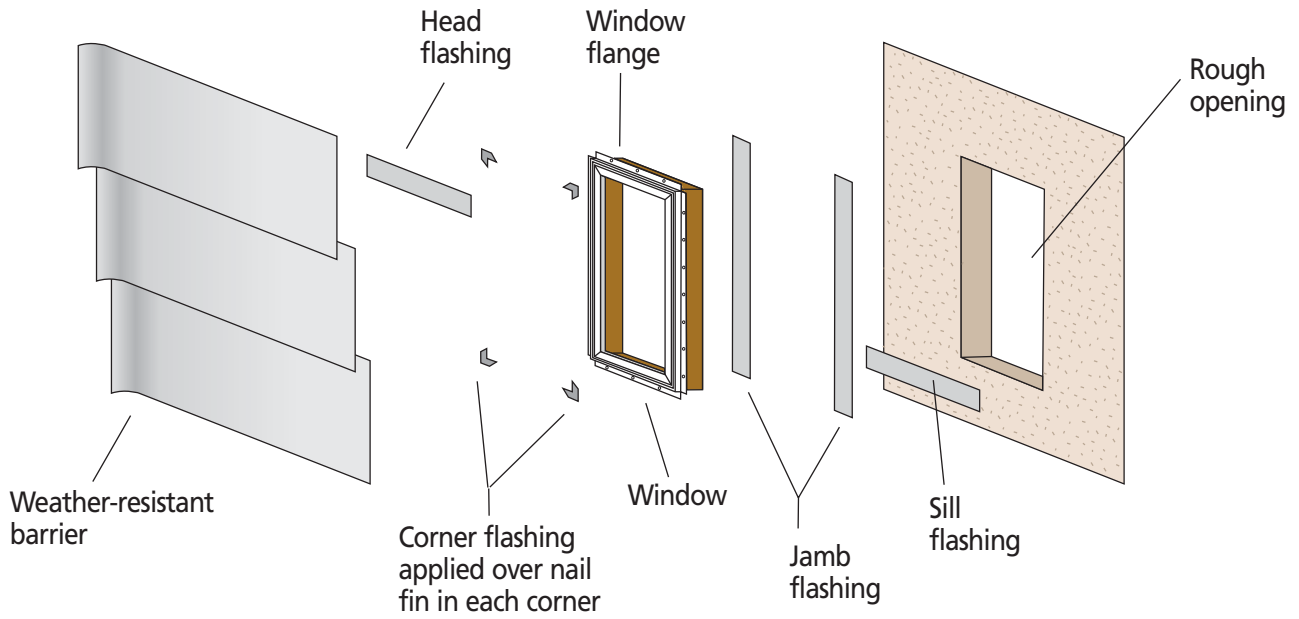

### STEP 3

#### Prepare rough opening.

Verify that the rough opening is plumb, level, square and sized appropriately.

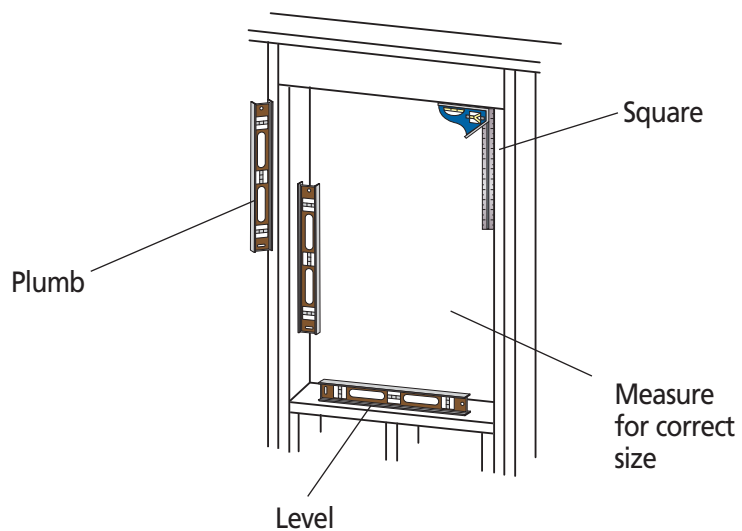

## STEP 4

### Cut and install sill flashing.

Cut the sill flashing long enough to extend beyond the jamb flashing pieces to be applied later. Wipe the surface of the weather-resistant barrier with a clean rag to ensure proper adhesion. Staple at the top edge of the flashing **ONLY** underneath the rough opening.

How to determine correct length of sill flashing:

Rough opening width + 9" overlap for each side. Using 9" flashing, this should equal rough opening width + 18".

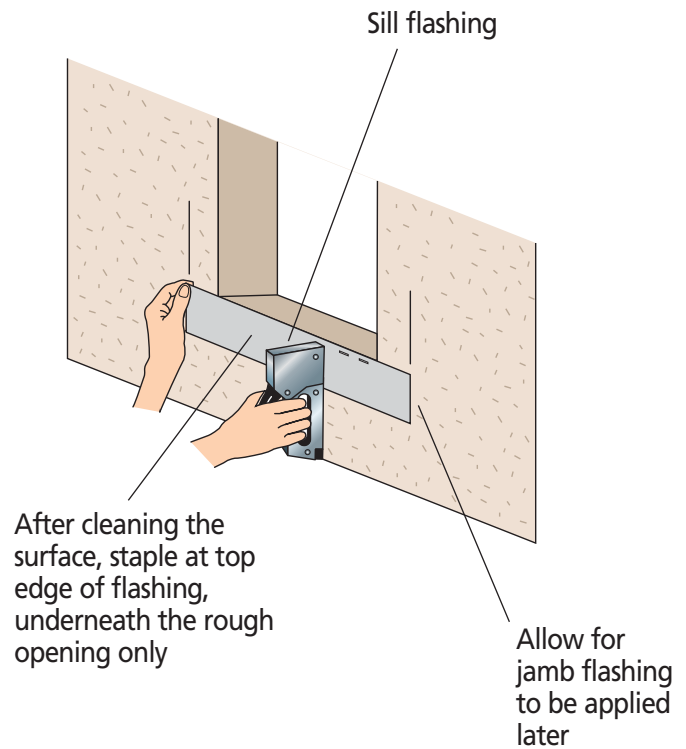

## STEP 5

### Cut and install jamb flashing.

How to determine correct length of jamb flashing:

Rough opening height + twice the width of the flashing, less 1/2" for top and 1/2" for bottom. Using 9" flashing, this should be rough opening height plus 17".

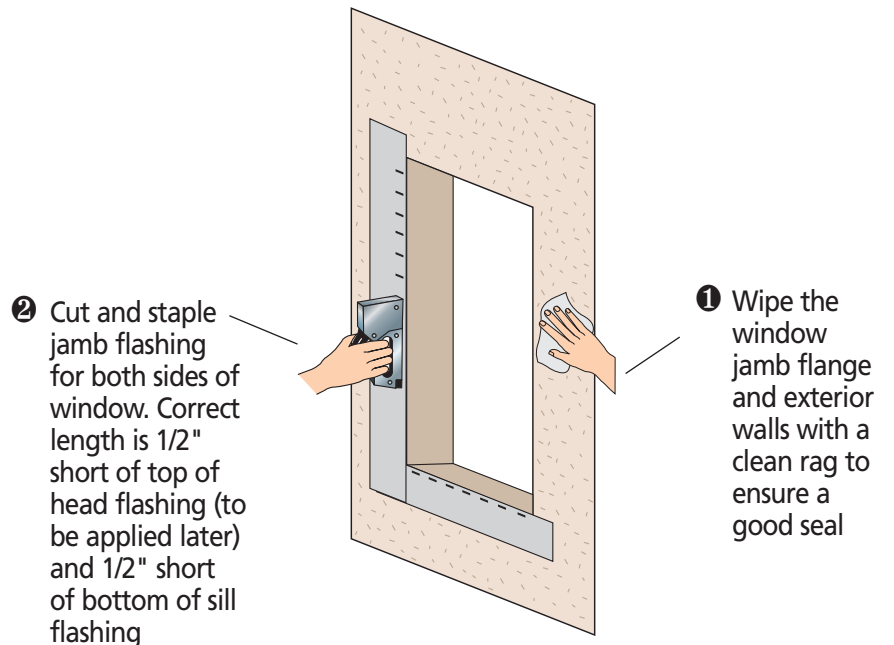

## STEP 6

### Apply sealant.

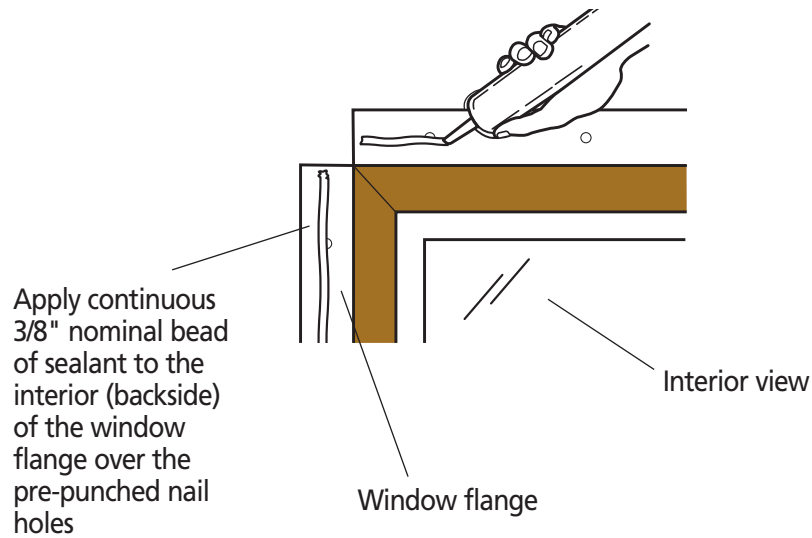

## STEP 7

### Install impervious shims on bottom.

On the bottom of the window opening, place 1" wide shims 1" from each side and every 12" along width of window. Spacers are required on each side of windows that are joined in multiple-window applications.

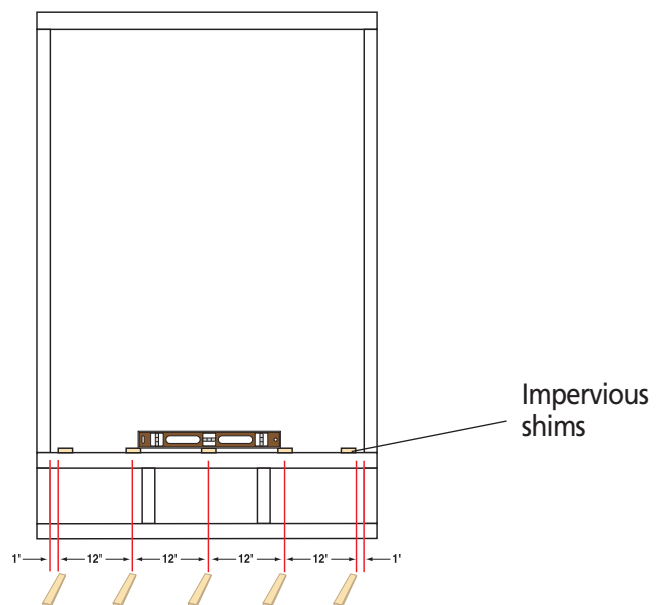

## STEP 8

### Tack window in place.

Insert the window from the exterior. Place the bottom of the window on the spacers and tilt the top into position. Center the window between the sides of the opening to allow for shimming.

Insert one galvanized nail into each corner of nail fin to secure window while shimming window plumb, level, square and true

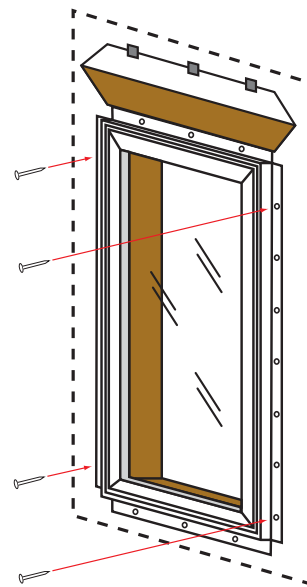

## STEP 9

### Insert shims on both sides.

③ Adjust the shims as needed to plumb and square the window

② Add additional shims at the midpoint and every 12" O.C.

Interior view

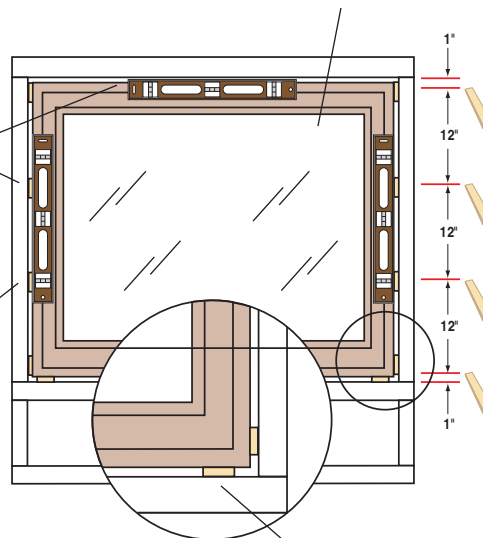

① Place shims 1" from the top and bottom of the window on each side

**Eagle**  
WINDOWS DOORS  
an Andersen Company



## STEP 10

Nail into place.

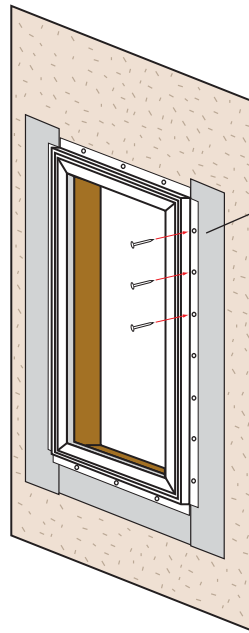

Fasten the window to the opening by driving a galvanized nail into each pre-punched hole in the nail fin

## STEP 11

Apply sealant.

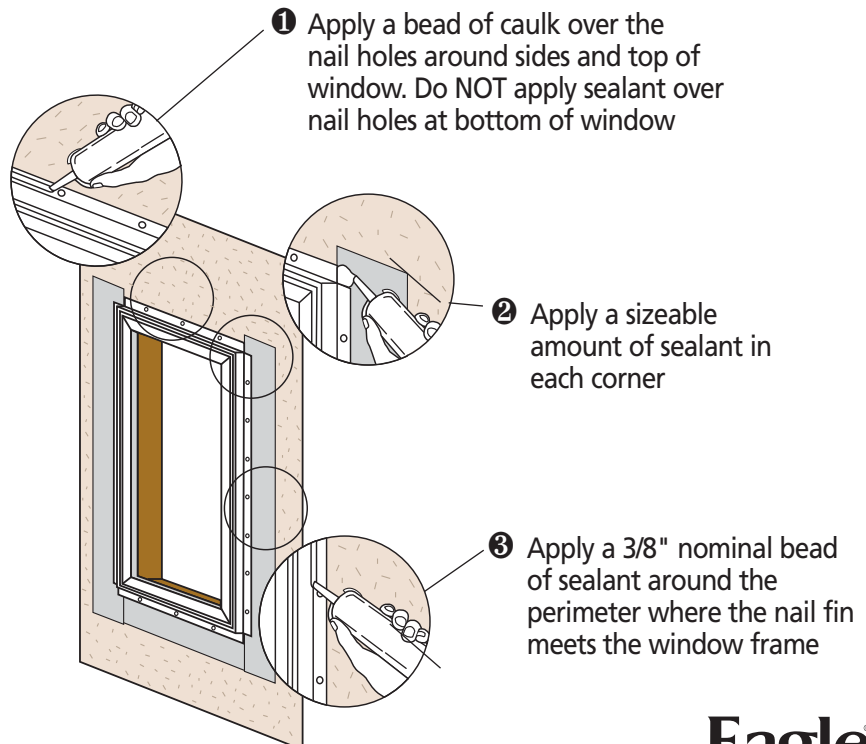

1 Apply a bead of caulk over the nail holes around sides and top of window. Do NOT apply sealant over nail holes at bottom of window

2 Apply a sizeable amount of sealant in each corner

3 Apply a 3/8" nominal bead of sealant around the perimeter where the nail fin meets the window frame



## STEP 12

Apply corner pad flashing to all four corners of nailing fin.

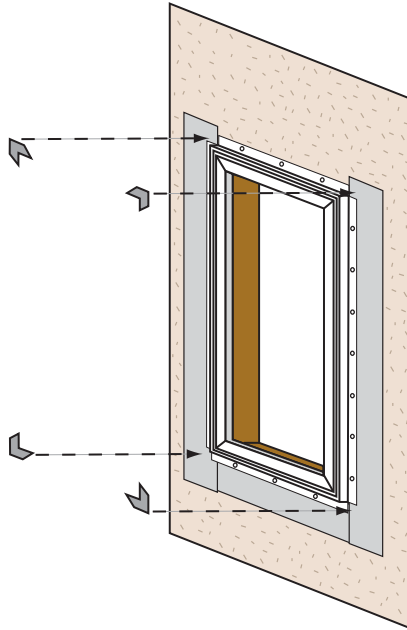

## STEP 13

Cut and install head flashing.

How to determine correct length of head flashing:

Rough opening width + twice the jamb flashing width + 1" overlap for each side. Using 9" flashing, this should be rough opening width + 20".

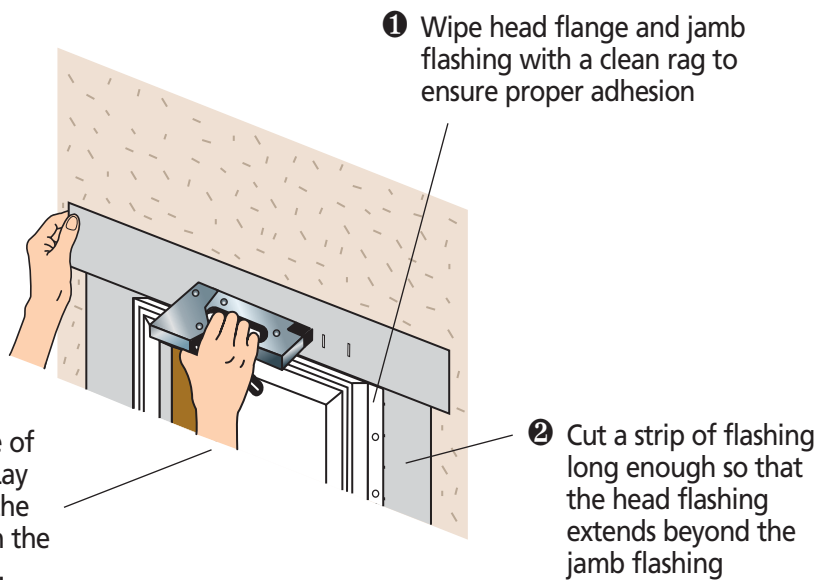

1 Wipe head flange and jamb flashing with a clean rag to ensure proper adhesion

2 Cut a strip of flashing long enough so that the head flashing extends beyond the jamb flashing

3 Staple top edge of head flashing. Lay the bottom of the head flashing in the bead of sealant.



## STEP 14

### Apply weather-resistant barrier.

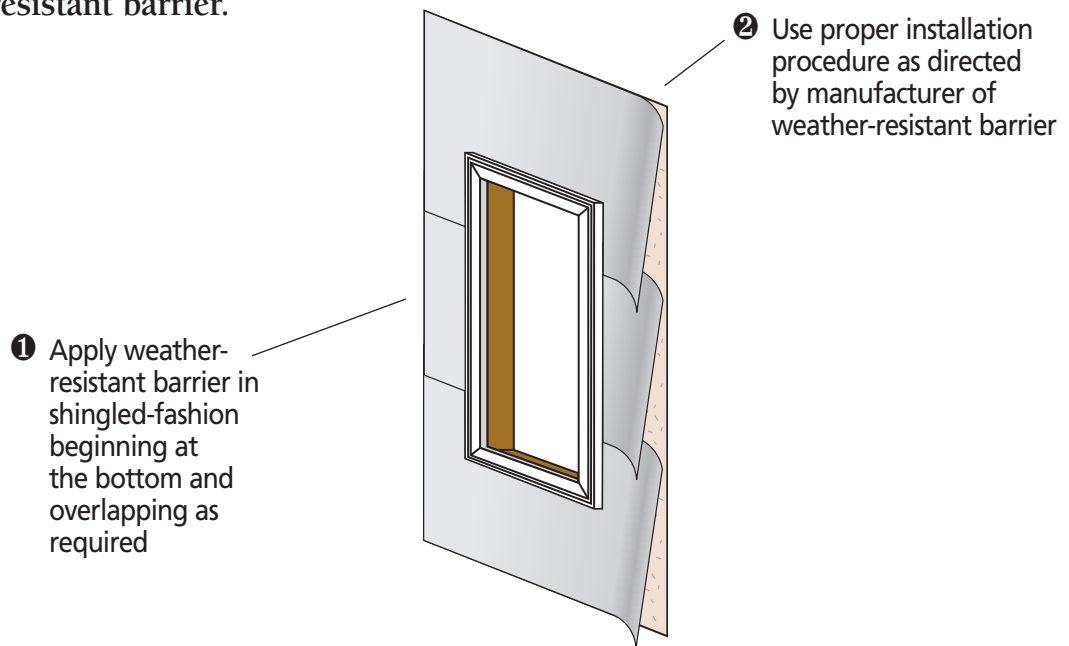

## STEP 15

### Apply Great Stuff Pro® Window & Door Insulating Foam Sealant from interior.

*NOTE: When applying siding or other exterior finish material, leave adequate space between the window frame and exterior finish material. See your sealant supplier for recommendations and instructions for these and other applications.*

**DO NOT** completely fill the space between the nail fin and the interior face of the opening

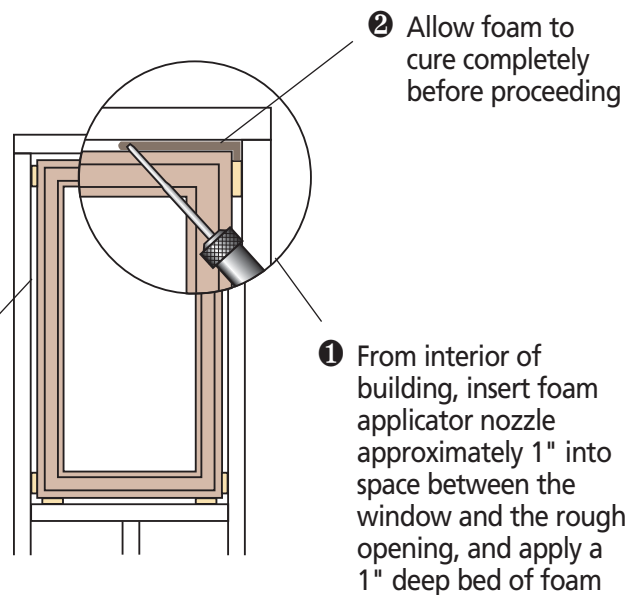

**STEP 16 – OPTION 1**

**Insert backer rod.  
(Wood siding application)**

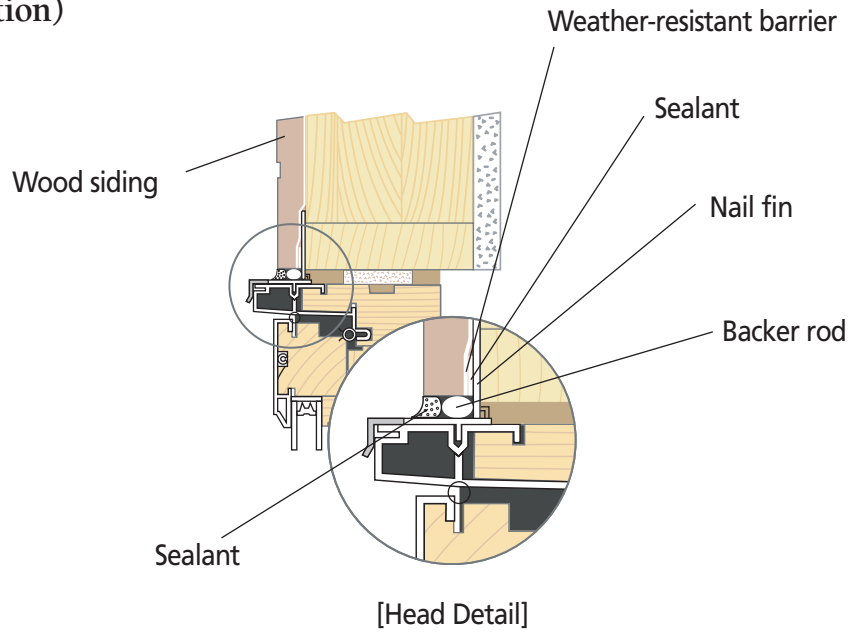

**STEP 16 – OPTION 2**

**Insert backer rod.  
(Vinyl or aluminum siding application)**

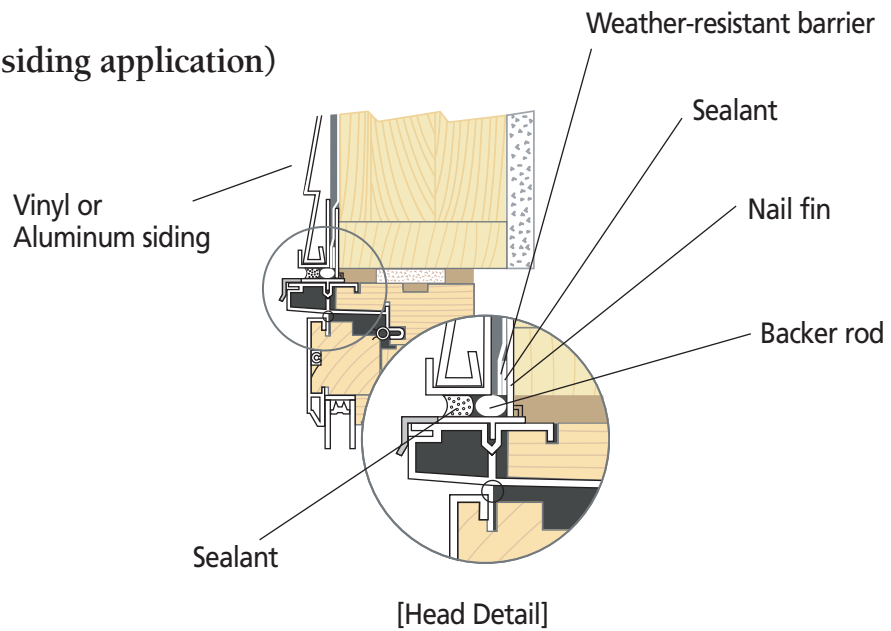

**STEP 16 – OPTION 3**

**Insert backer rod.  
(Brick exterior application)**

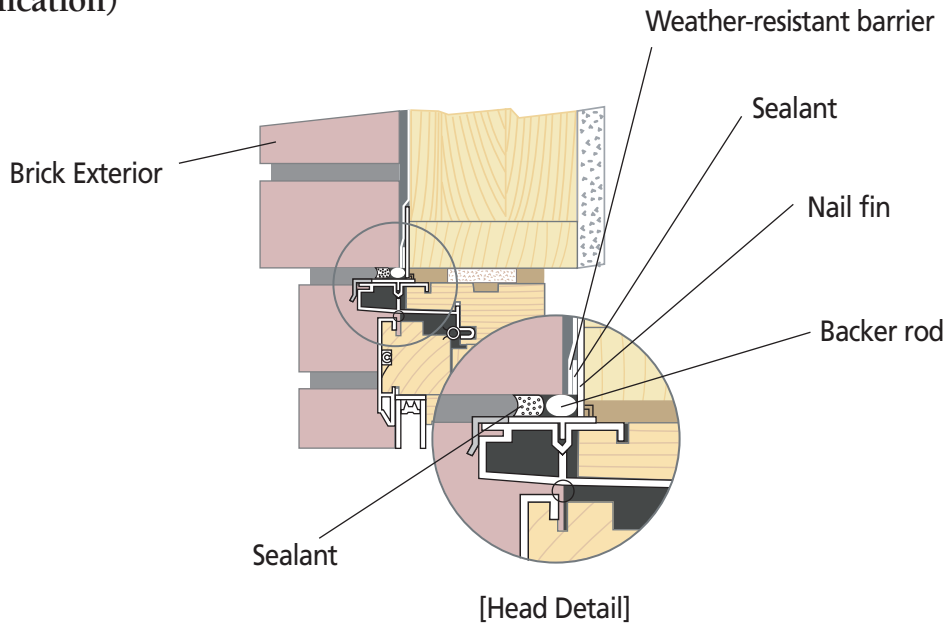

**STEP 16 – OPTION 4**

**Insert backer rod.  
(Wood siding and trim application)**

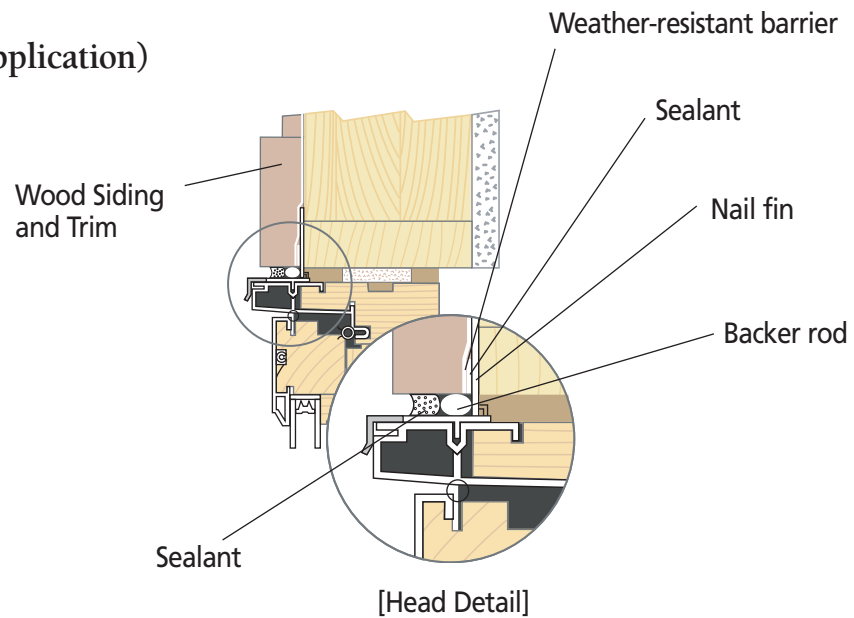

## STEP 17

### Apply sealant.

*NOTE: When applying siding or other exterior finish material, leave adequate space between the window frame and exterior finish material. See your sealant supplier for recommendations and instructions for these and other applications.*

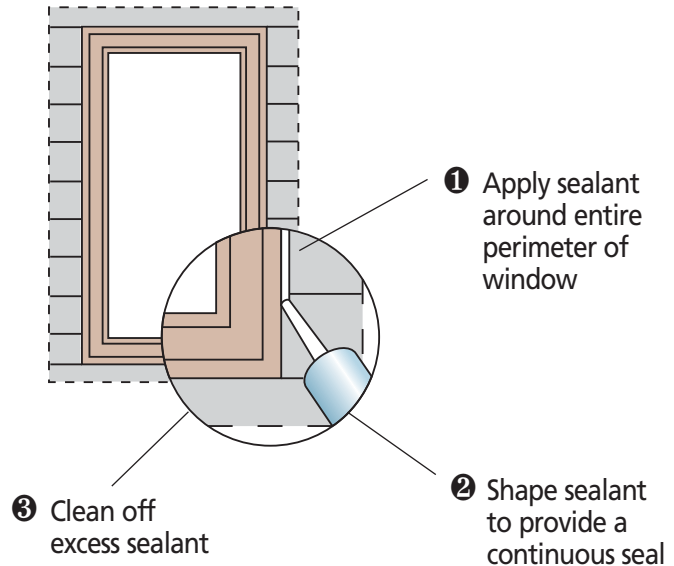

## STEP 18

### Prepare interior wood surfaces for finishing.

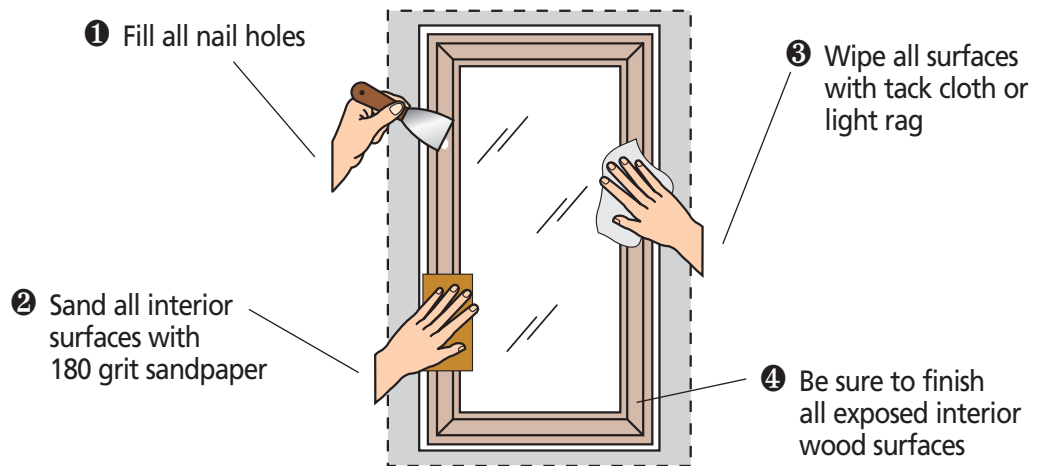

## STEP 19 – OPTION 1

### Finishing. (Applying paint.)

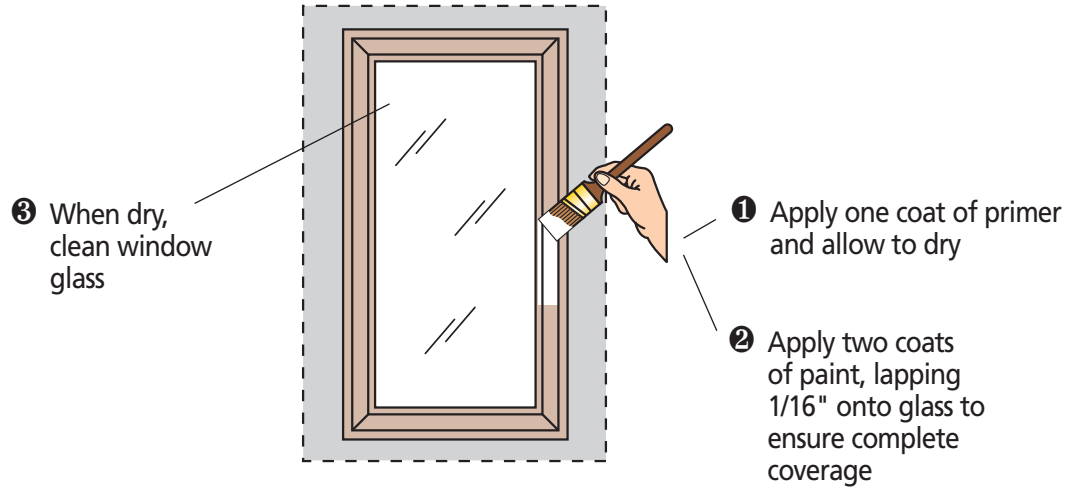

## STEP 19 – OPTION 2

### Finishing. (Applying natural finish.)

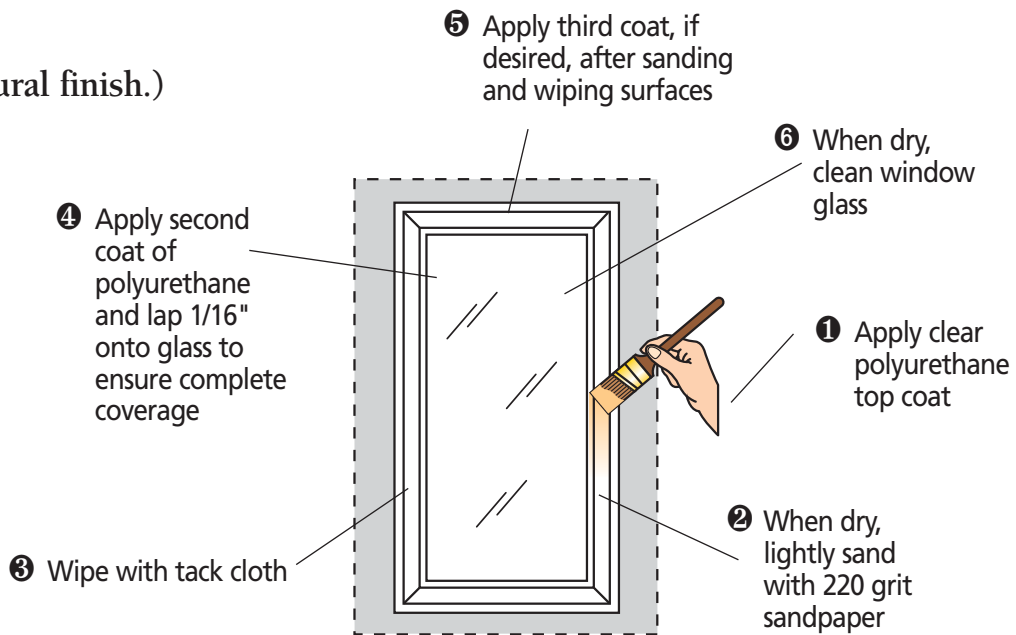

## See the Eagle Owner's Manual for care and maintenance information.

Methods and procedures for installation of siding and other cladding materials, trim, moldings and other finish materials around window openings are not specified in these instructions. Such materials should be installed in conformity with the manufacturer's specifications and/or industry standards for such materials. If masonry cladding is used, the soldier course of masonry must be one-half inch away from the bottom of the sill on all windows.

Because all construction must anticipate some water infiltration, it is important that the wall system be designed and constructed to properly manage moisture. Eagle Window & Door is not responsible for claims or damages caused by unanticipated water infiltration, deficiencies in building design, construction and maintenance, failure to install Eagle products in accordance with these instructions, or the use of Eagle products in systems which do not allow for proper management of moisture within the wall system. The determination of the suitability of all building components, including the use of Eagle products, as well as the design and installation of flashing and sealing systems, are the responsibility of you, your architect, or a construction professional. Moisture problems, including unacceptable water infiltration, have been associated with barrier systems such as EIFS (also known as synthetic stucco). Eagle products should not be used in barrier EIFS systems unless Eagle's current, recommended installation procedures for installation of windows and doors into EIFS are used. Any other use of Eagle products with barrier EIFS systems will void the warranty.

Contact your sealant supplier to choose a sealant that is compatible with, and that will adhere adequately to, all building materials used in the window area. Important: Perimeter sealant must be Grade NS Class 24 per ASTM C920 and compatible with the window/door product, nail fin and the finished exterior of the building. Use of improper sealant could result in sealant failure, resulting in air and water infiltration.

Eagle makes no warranty, expressed or implied, that the methods and procedures described in these instructions are suitable for any particular purpose or installation. These instructions do not add to or modify the terms, conditions or limitations of Eagle's manufacturer's warranty.

A drip cap is required on all windows and doors. Failure to utilize and incorporate a drip cap could void the Eagle Window & Door warranty. Refer to the Eagle warranty for additional information.

These installation procedures have been tested by an independent laboratory under ideal installation conditions using the ANSI/AAMA/NWDA 101/I.S. 2-97 test method for installation, and meet DP50 performance levels for installation only.

Note: E-Z Seal is a registered trademark of Fortifiber Corporation.

