



Eagle high-performance mullion

instructions for units mullied together with LVL reinforcement and installed using Type B clips

These instructions are for typical installation in new typical **wood frame wall construction**. These instructions and methods are not intended for use in other construction types or for replacement installations. These instructions and methods may not be appropriate for a specific installation due to design of the building, construction methods used, building conditions or site conditions, any of which may require different methods or procedures. You and your architect or installing contractor are responsible for determining the method and procedures appropriate to your specific installation.

The installation instructions included as part of these mullion instructions are not representative of a specific window type. Specific product installation instructions must be strictly followed to ensure proper installation. These mulling instructions apply to clad products only. All assemblies must be installed using a 1/2" R.O. For instructions using other mullion materials and/or clips, see the "Installation" section at EagleWindow.com

STEP 1

Be sure you have all tools required:



Tape measure



Level



Square



Nylon block



Hammer

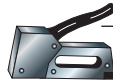

Stapler



Rubber mallet



Utility knife or scissors



Power drill and bits



Wood clamps



Nail set

STEP 2

Be sure you have a sufficient supply of all materials required: Take care to anticipate all material needs before beginning work. Additional materials may be needed in any particular installation.



Shims or spacers made of cedar or other impervious material

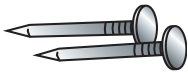

2" galvanized roofing nails
(1/4 pound per window)



Screws of various sizes, as required by installation.
(See Steps 13 and 20)



Closed-cell foam backer rod or sealant backer
(12' to 30' per window)



Moistop, 6" E-Z Seal® Flashing

For more information, visit:
www.fortifiber.com

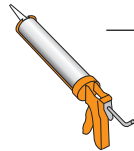

High quality exterior grade silicone sealant



Great Stuff Pro™ Window & Door Insulating Foam Sealant

For more information, visit:
www.dow.com



Mullion end cap
(two per mullion reinforcement)

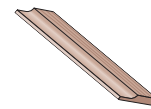

Interior trim and/or jamb extensions
(15' to 40' per window)

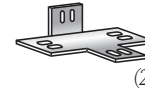

Type B clips
(2 per mullion reinforcement)

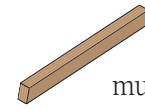

LVL material for mullion reinforcement
(correct length is equal to length of window unit)

STEP 3

Prepare rough opening.

Verify that the rough opening is plumb, level, square and sized appropriately.

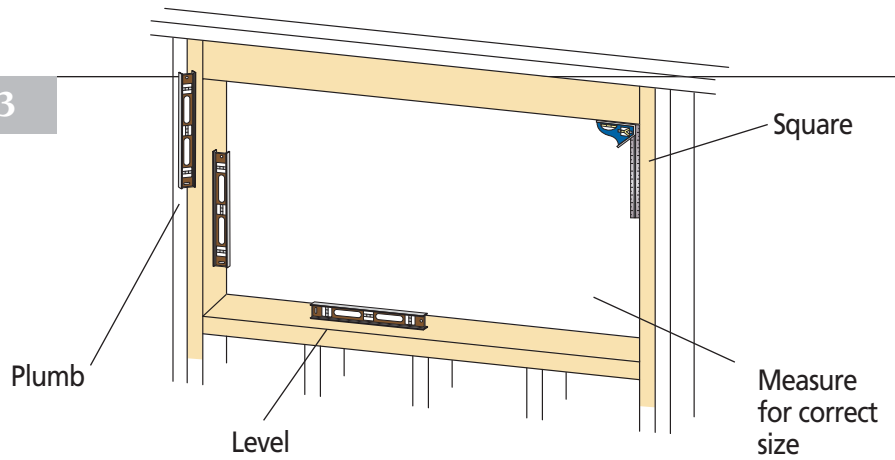

STEP 4

Cut weather-resistant barrier.

5 5th cut – Make a 6" cut up from each top corner at a 45° angle to allow the weather barrier to be lapped over the fin at the head of the window

4 4th cut

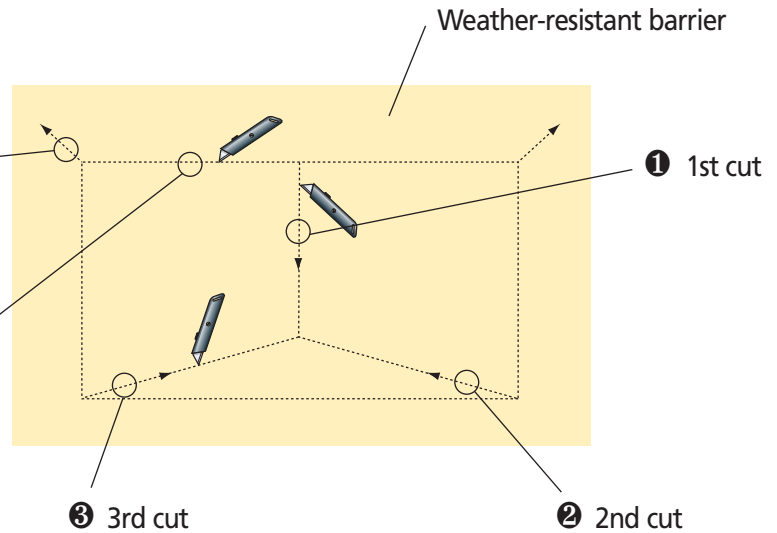

STEP 5

Secure weather-resistant barrier.

Fold sides and bottom flaps of the weather-resistant barrier into the opening and staple to inside wall. Fold top flap up and temporarily fasten with tape as shown.

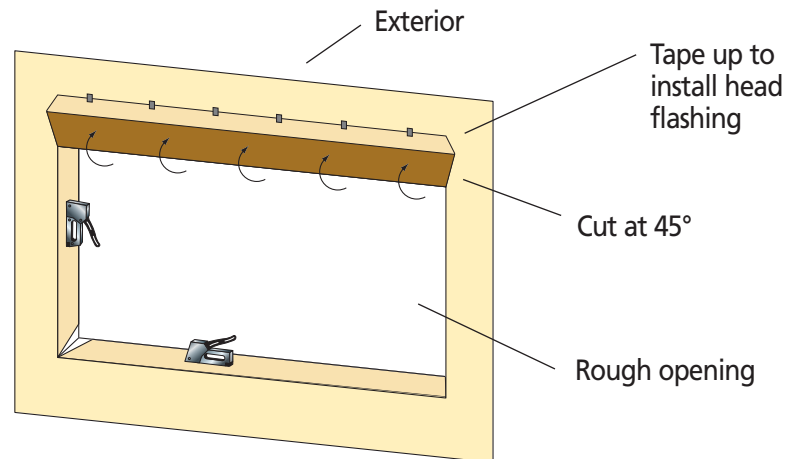

STEP 6

Cut and install sill flashing.

Cut the sill flashing long enough to extend beyond the jamb flashing pieces to be applied later. Wipe the surface of the weather-resistant barrier with a clean rag to ensure proper adhesion. Remove the release paper and press the sill flashing in place so that the edge of the flashing's adhesive is level with the top edge of the rough opening.

How to determine correct length of sill flashing:

Rough opening width + 6" overlap for each side. Using 6" flashing, this should equal rough opening width + 12".

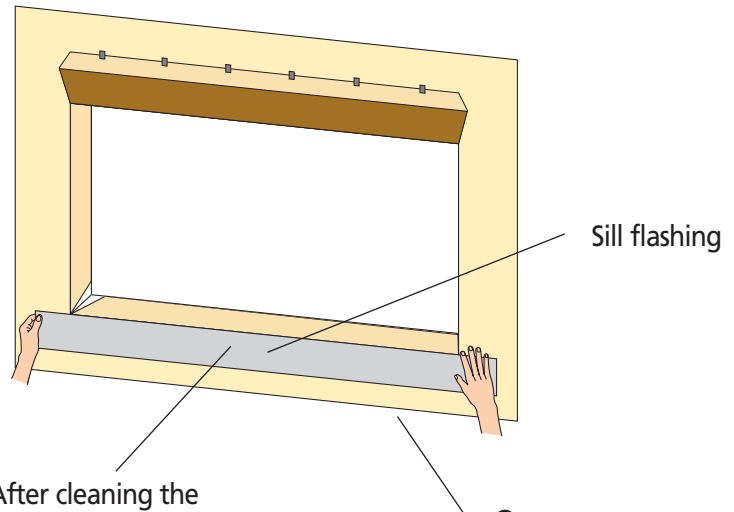

② After cleaning the surface, press sill flashing firmly into place with adhesive edge flush with top of rough opening

① Allow for jamb flashing to be applied later

STEP 7

Remove interior stops from all window units to be mullied.

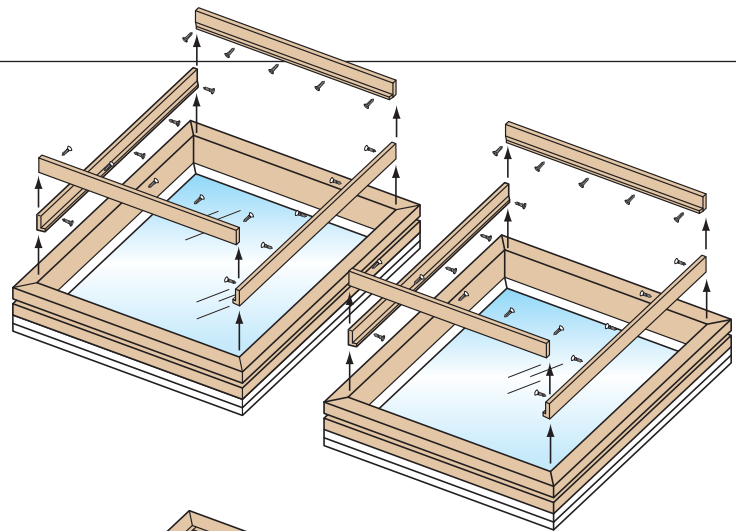

STEP 8

Place units face down (wood interior of windows up) and align. Take care to protect exterior face of windows.

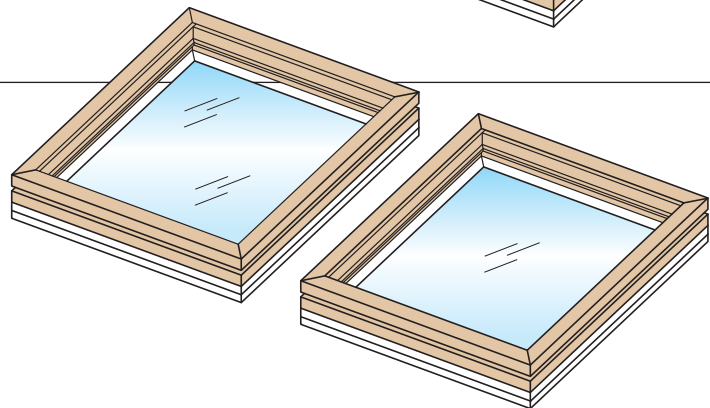

STEP 9

Apply sealant.

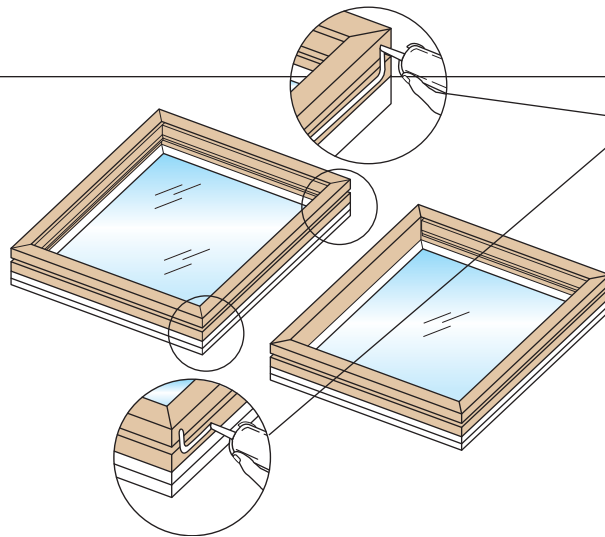

Apply 3/8" nominal bead of sealant 1-1/2" behind accessory groove on both units. Apply on length of frame and across width at top and bottom.

STEP 10

Measure and cut required length of LVL mullion. Correct length of reinforcement is equal to length of window unit.

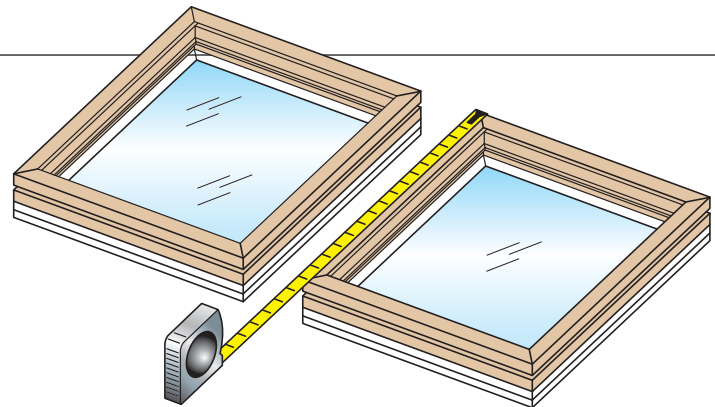

STEP 11

Align mullion with one unit, using wood block to achieve proper setback from exterior face of window unit.

Proper setback of mullion from exterior face of cladding is: Casement, awning, auxiliary, double-hung, outswing door, French sliding door, patio door – 1-5/16".
Inswing door – 2-1/4"

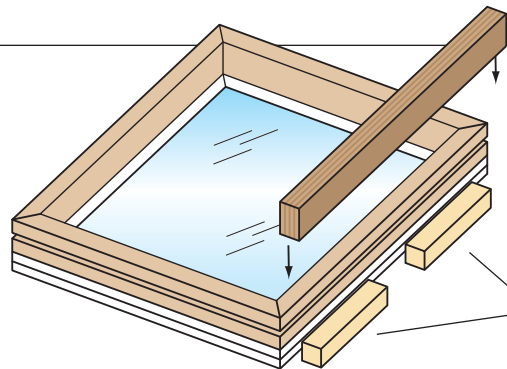

Use wood blocks to create proper setback

STEP 12

Clamp mullion to window unit.

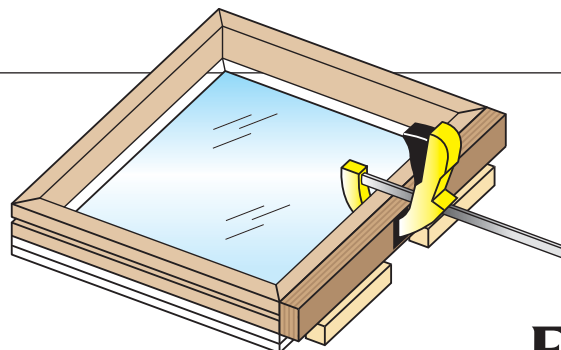

STEP 13

Fasten using required screws and spacing, per charts below.

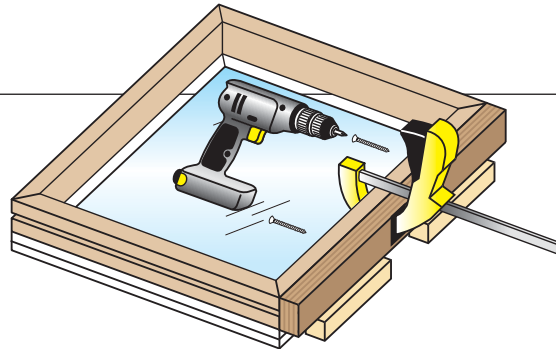

Mullion Fastener Charts

These tables show the maximum fastener spacing for a #8 wood screw with 1-3/16" penetration into the substrate. Screws must be located 6" from each corner, and as noted in the tables below. If the recommended fastener spacing is longer than the jamb, use two screws per jamb, 6" from each corner.

Fastener spacing (in inches) for double-hung, sliding windows, inswing and sliding doors

		Product Size (inches)												
		24	28	32	36	40	44	48	52	56	60	64	68	72
Maximum Design Pressure (psf)	25	24	24	24	24	24	24	24	24	24	24	24	24	23
	50	24	24	24	23	21	19	17	15	15	14	13	12	12
	75	23	20	17	15	14	13	12	11	10	9	9	8	8
	100	17	15	13	12	10	9	9	8	7	7	6	6	6

Fastener spacing (in inches) for auxiliary, casement, awing and fixed windows and outswing doors

		Product Size (inches)												
		24	28	32	36	40	44	48	52	56	60	64	68	72
Maximum Design Pressure (psf)	25	24	24	24	24	24	24	24	24	24	24	24	24	24
	50	24	24	24	24	24	24	22	20	19	18	16	16	15
	75	24	24	22	20	18	16	15	14	13	12	11	10	10
	100	22	19	16	15	13	12	11	10	9	9	8	8	7

NOTE: Use these tables for each dimension. For example, for a 2'0" x 5'0" casement unit with a DP50, the fastener spacing is 24" on the head and sill, and 18" on the jambs.

Jamb to Rough Opening Fasteners

- 1/4" maximum shim space – use to fill the space and at each screw location
- 2-3/4" recommended screw length for auxiliary, casement, casement fixed, awning windows and outswing doors
- 2-1/4" recommended screw length for double-hung and sliding windows, sliding and inswing doors

Jamb to Mullion Reinforcement Fasteners

- Recommended screw length for auxiliary, casement, casement fixed, awning windows and outswing doors
- 1" LVL = #8 x 2-1/4"
 - 2" LVL = #8 x 2-1/2"

Recommended screw length for double-hung and sliding windows, sliding and inswing doors

- 1" LVL = #8 x 1-3/4"
- 2" LVL = #8 x 2"

	Into wood header	Into masonry header	Into 1" LVL mullion reinforcement	Into 2" LVL mullion reinforcement	Into 1" x 3" Tube Steel	Into 2" x 4" Tube Steel
Type A Clips	#10 x 1-1/2" ssfhws	1/4" x 1-3/4" tapcon	#10 x 1" ssfhws	#10 x 1-1/2" ssfhws	Do not use	Do not use
Type B Clips	#10 x 1-1/2" ssfhws	1/4" x 1-3/4" tapcon	#10 x 1-1/2" ssfhws	#10 x 1-1/2" ssfhws	#10 x 3/8" sssts	#10 x 3/8" sssts
Type F Clips	#10 x 1-1/2" ssfhws	1/4" x 1-3/4" tapcon	Do not use	Do not use	Do not use	Do not use

ssfhws = Stainless steel flat head wood screw
 sssts = Stainless steel self tapping screw



STEP 14

Remove wood clamps.

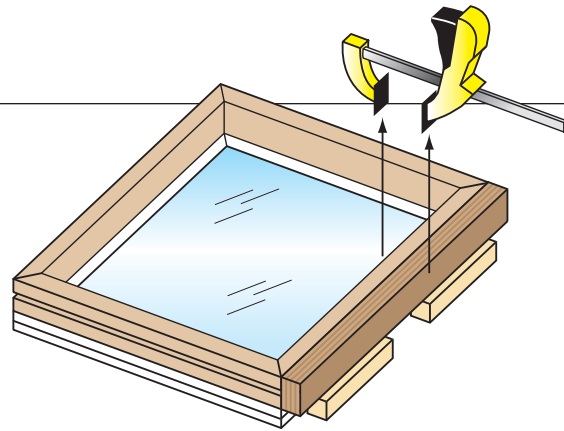

STEP 15

Align second unit, adjust for proper setback and clamp.

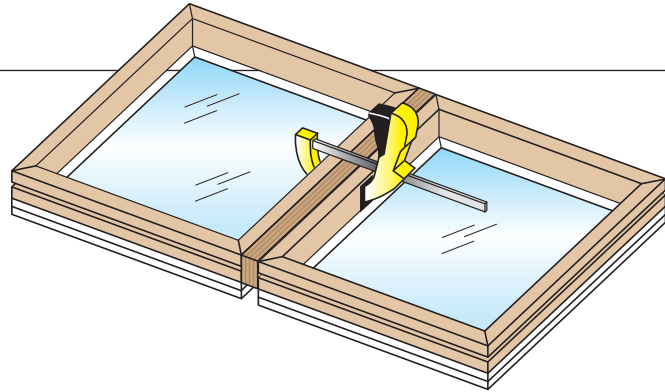

STEP 16

Fasten second unit, using required screws and spacing, per chart in Step 13.

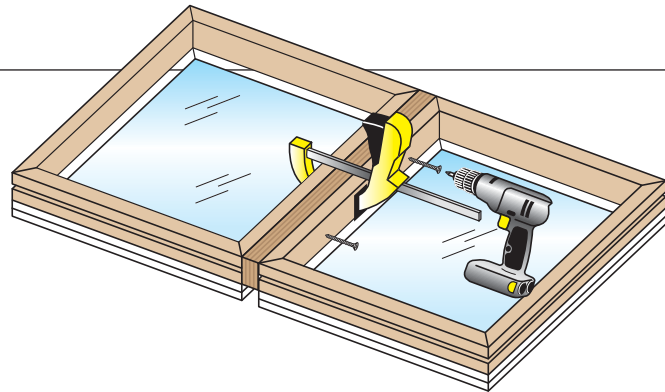

STEP 17

Apply extension jamb on interior as necessary.

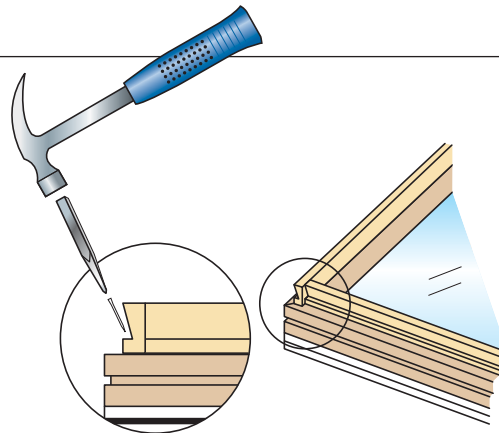

STEP 18

Apply nailing flange into groove on perimeter of window units.

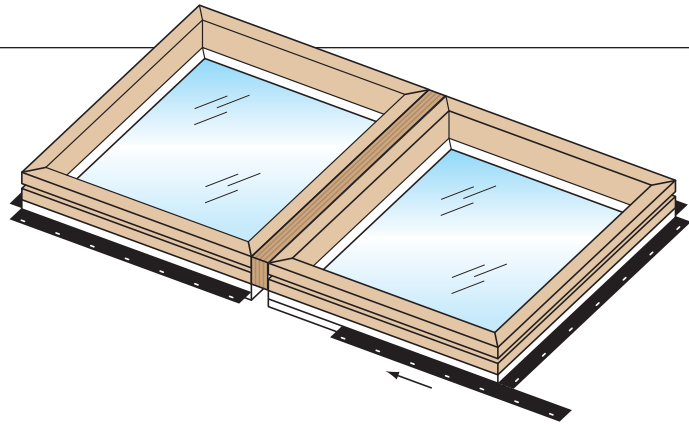

STEP 19

Apply sealant to back (inside) of nailing flange.

Apply 3/8" nominal bead of sealant over the pre-punched nail holes

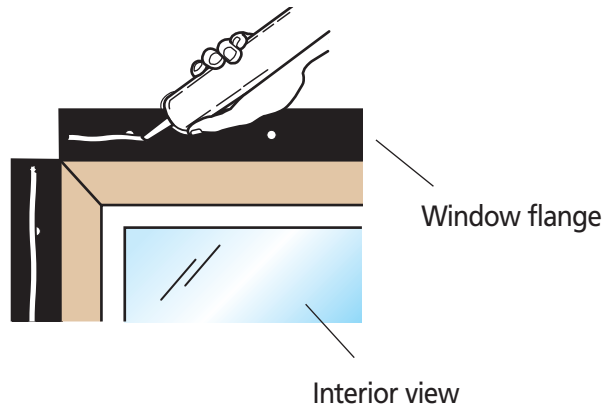

STEP 20

Locate and install type B clip on each side of rough opening (top & bottom or left & right). Be sure set-back dimension is correct, as follows:

Use correct fasteners: For header, use #10 x 1-1/2" stainless steel flat head wood screw, or 1/4" x 3/4" tapcon for masonry. For fastening into LVL mullion reinforcement, use #10 x 1-1/2" stainless steel flat head wood screws.

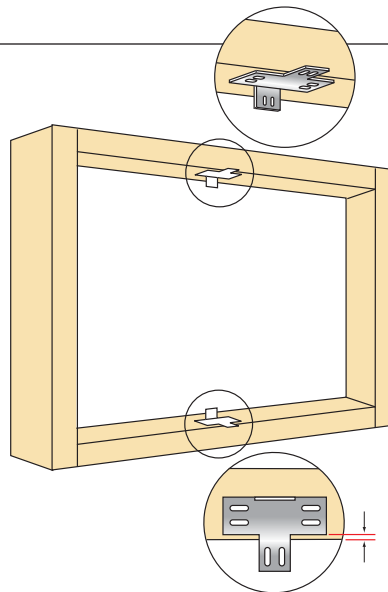

1" x 3-1/2" LVL = 3/4" setback
2" x 3-1/2" LVL = 1/4" setback

NOTE: If installing windows from exterior, raised (straight) leg of clip is on interior side.
If installing from interior, raised leg is on exterior side.



STEP 21

Slide windows into the rough opening and temporarily secure into place.

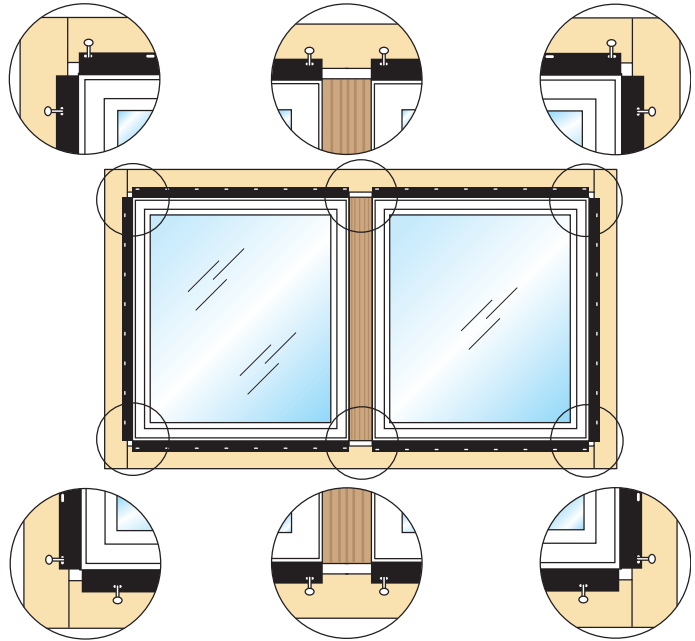

STEP 22

Shim the unit so it is square, plumb and level.

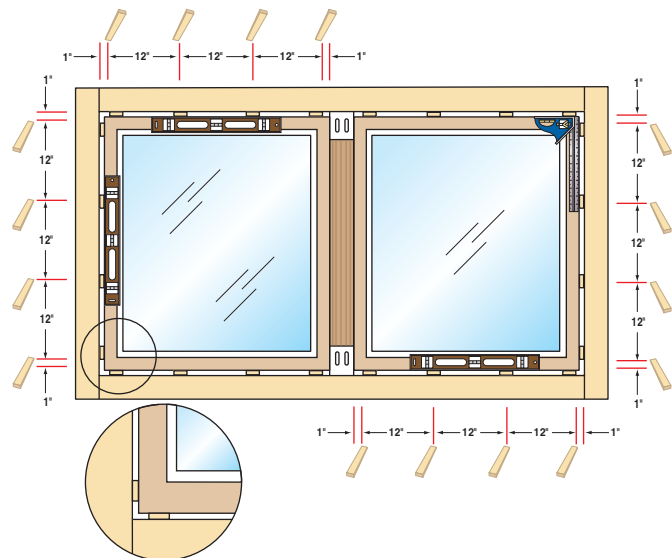

STEP 23

Fasten the interior leg of the clip to the mullion. See Step 20 for correct fastener size.

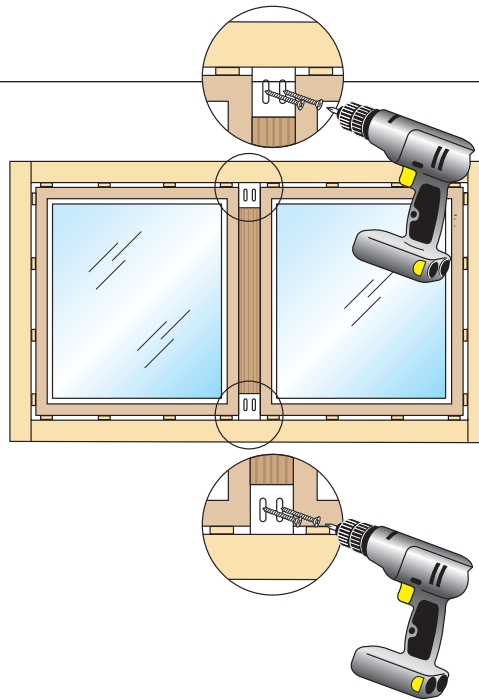

STEP 24

Bend exterior leg of each clip around mullion and fasten.

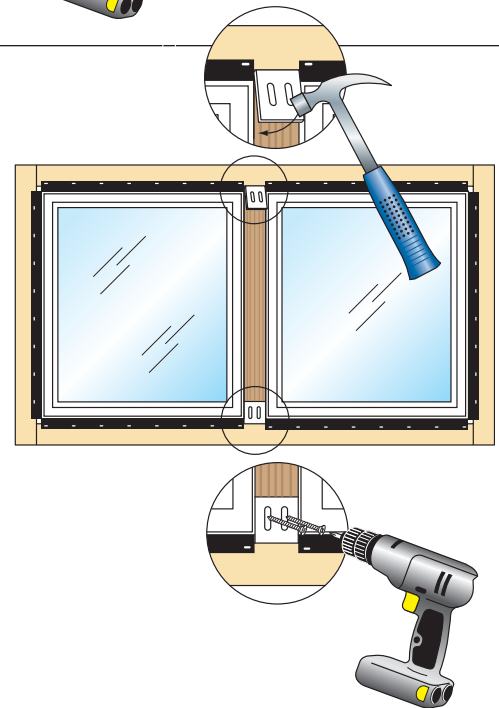

STEP 25

Drive screws through window frame into rough opening on all sides of perimeter.

Refer to page 5, Step 13 for correct fastener size.

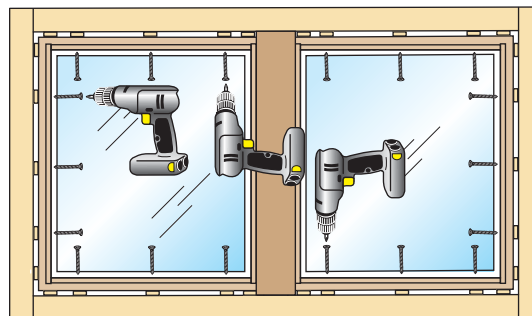

STEP 26

Re-apply stops using finish nails.

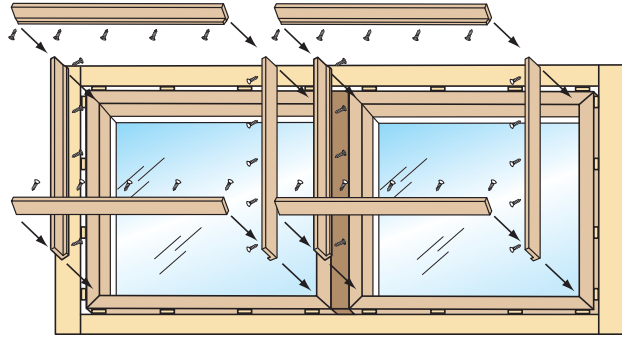

STEP 27

Apply interior mull cover.

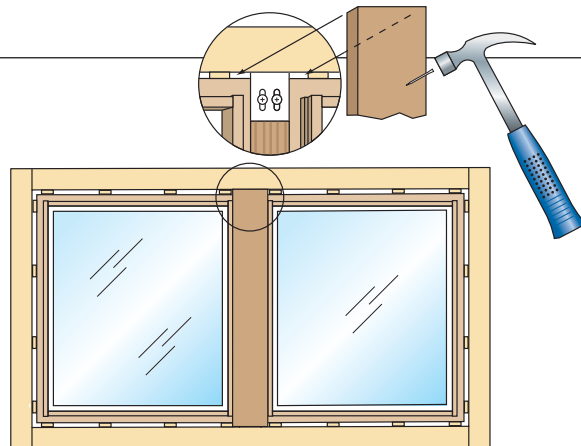

STEP 28

Apply nails in pre-punched holes to effectively secure nail fin over weather-resistant barrier.

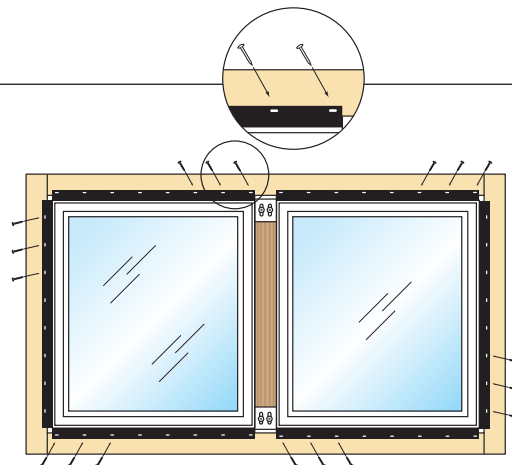

STEP 29

Apply sufficient sealant to effectively seal the window and mullion. Tool sealant over entire width of mullion to achieve smooth bead.

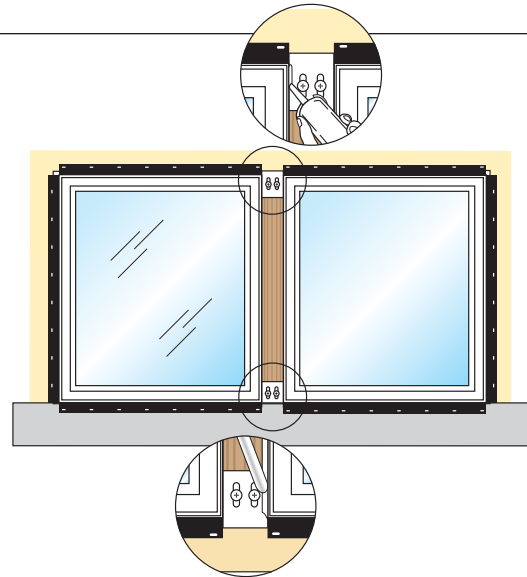

STEP 30

Install mullion end cap at top & bottom for vertical mullions and left & right for horizontal mullions.

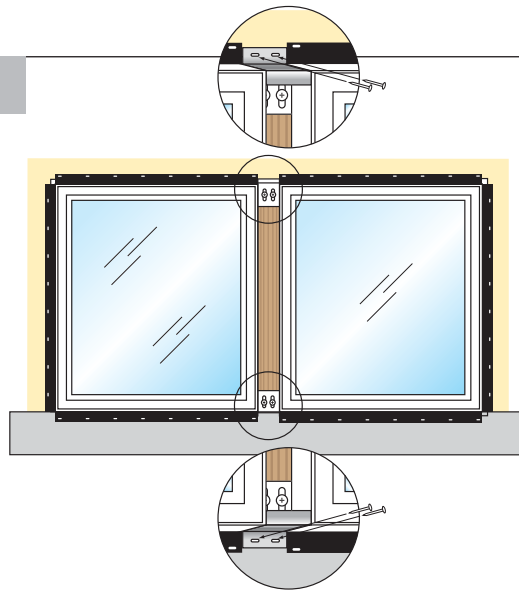

STEP 31

Apply sealant across top leg and protruding leg of end cap. Do NOT apply sealant at horizontal sill on vertical mullions.

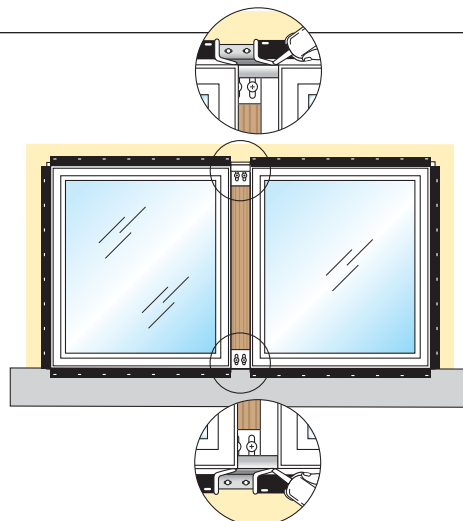

STEP 32

Measure required length of exterior mull cover and cut.

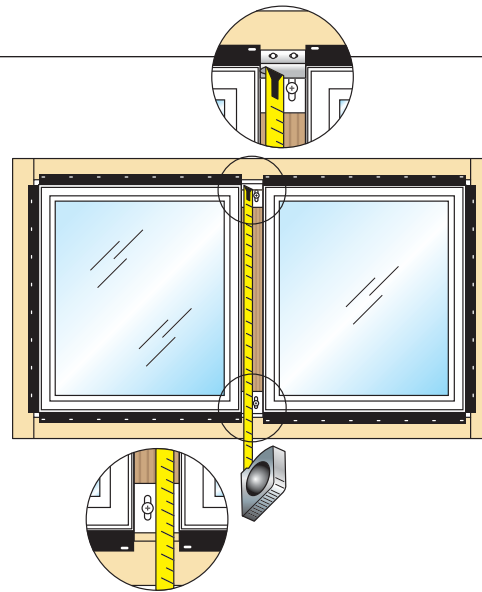

STEP 33

Apply exterior mull cover starting at the bottom right and top left working towards the center using a nylon block and rubber mallet.

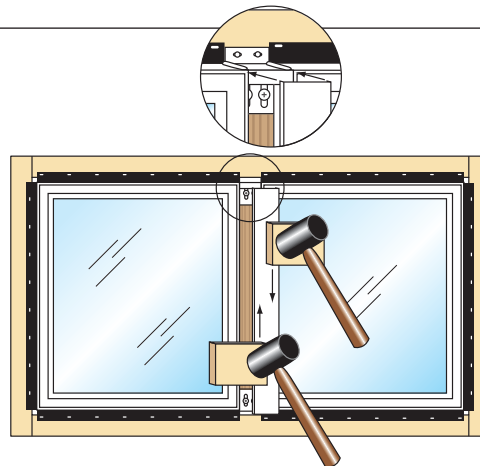

STEP 34

Wipe any excess sealant off both units.

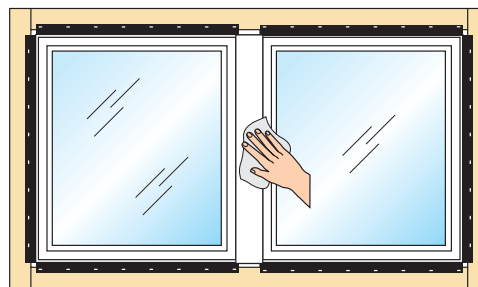

STEP 35

At mullion ends, apply continuous bead of sealant over edge of mullion where it joins the window unit edge and where the window meets the mullion cap.

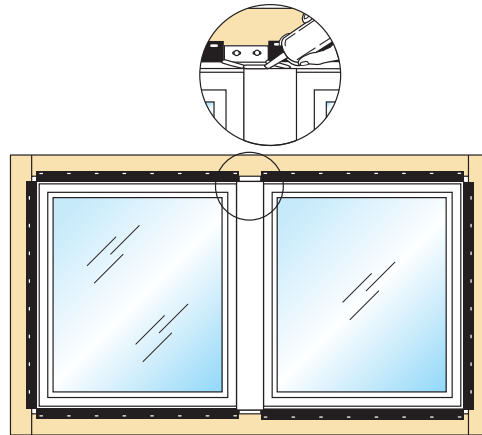

STEP 36

Apply a sizeable amount of sealant in each corner, and a 3/8" nominal bead of sealant around the perimeter where the nail fin meets the window frame.

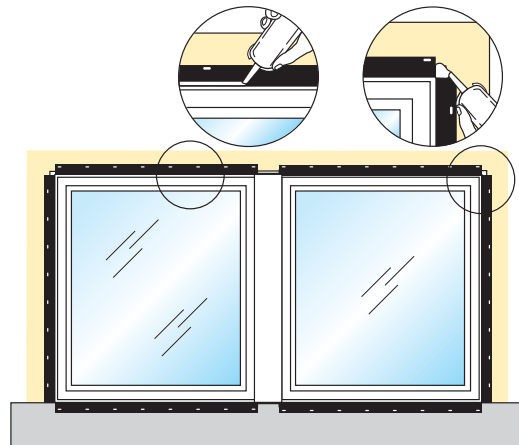

STEP 37

Apply corner pad flashing to the outside four corners.

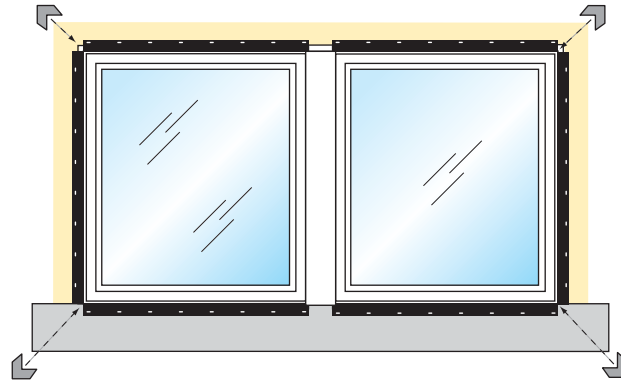

STEP 38

Cut and install jamb flashing.

How to determine correct length of jamb flashing:

Rough opening height + twice the width of the flashing, less 1/2" for top and 1/2" for bottom. Using 6" flashing, this should be rough opening height plus 11".

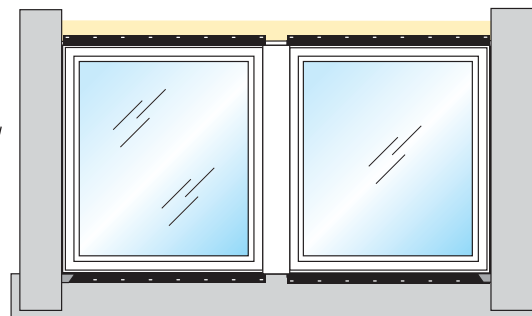

③ Align the flashing flush against the window frame with the adhesive strip covering the entire window flange and apply

② Cut and apply jamb flashing for both sides of window. Correct length is 1/2" short of top of head flashing and 1/2" short of bottom of sill flashing

① Wipe the window jamb flange and exterior walls with a clean rag to ensure proper adhesion



STEP 39

Cut and install head flashing.

How to determine correct length of head flashing: Rough opening width + twice the jamb flashing width + 1" overlap for each side. Using 6" flashing, this should be rough opening width +14".

- 1 Wipe head flange, jamb flashing and weather-resistant barrier with a clean rag to ensure proper adhesion

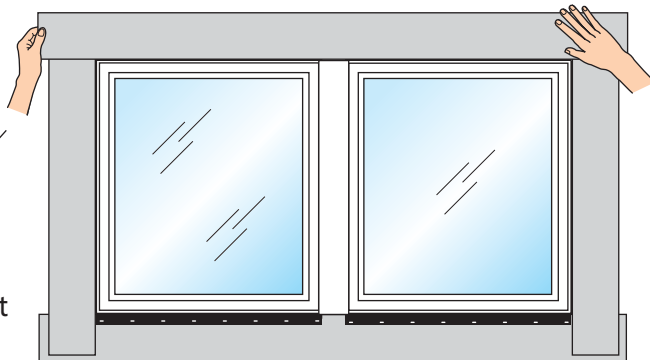

- 3 Install head flashing by pressing firmly in place in one direction

- 2 Cut a strip of flashing long enough so that the head flashing extends beyond the jamb flashing

STEP 40

Apply metal drip cap.

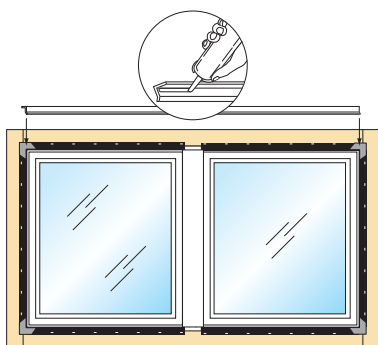

- 1 Apply sealant to top edge of back side of drip cap and the head of the window unit.

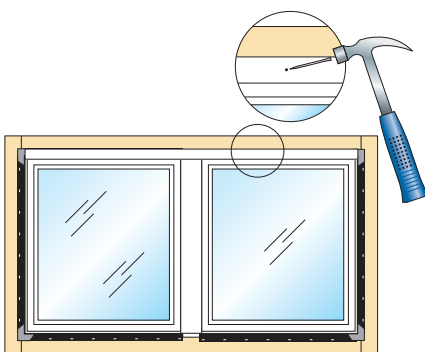

- 2 Nail drip cap into place, so that it covers entire width of mullied window units.

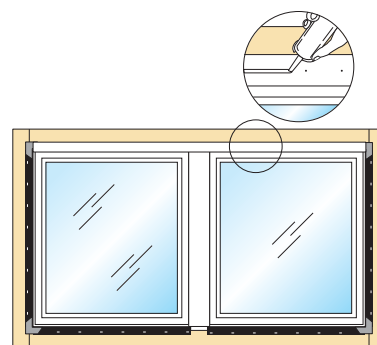

- 3 Apply sealant in line over nail holes.



STEP 41

Integrate flashing system into the weather-resistant barrier.

- 2 Apply a new piece of flashing over the entire diagonal cut made in the weather-resistant barrier and press into place

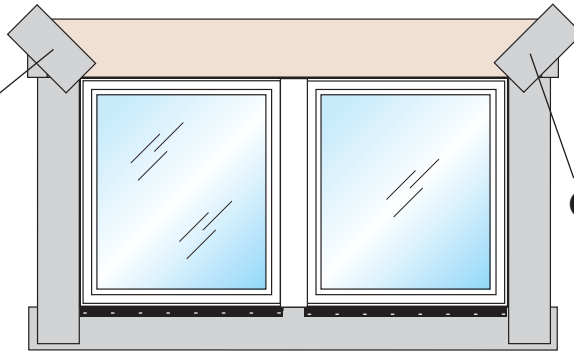

- 1 Make sure that the flap of the weather-resistant barrier lays flat over the head flashing and lays into the bead of sealant on the head flashing

STEP 42

Apply Great Stuff™ Pro Window & Door Insulating Foam Sealant from interior.

NOTE: When applying siding or other exterior finish material, leave adequate space between the window frame and exterior finish material. See your sealant supplier for recommendations and instructions for these and other applications.

DO NOT completely fill the space between the nail fin and the interior face of the opening

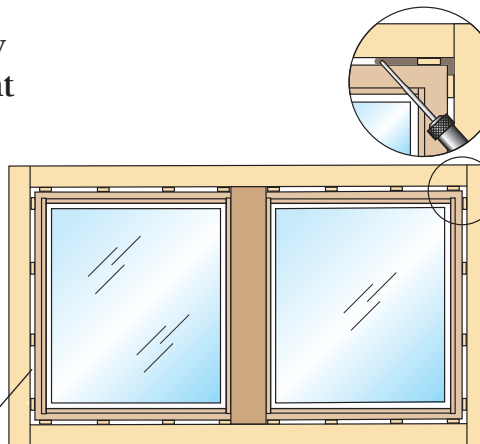

- 1 From interior of building, insert foam applicator nozzle approximately 1" into space between the window and the rough opening, and apply a 1" deep bed of foam
- 2 Allow foam to cure completely before proceeding



STEP 43

Apply backer rod and sealant around entire perimeter of window.

NOTE: When applying siding or other exterior finish material, leave adequate space between the window frame and exterior finish material. See your sealant supplier for recommendations and instructions for these and other applications.

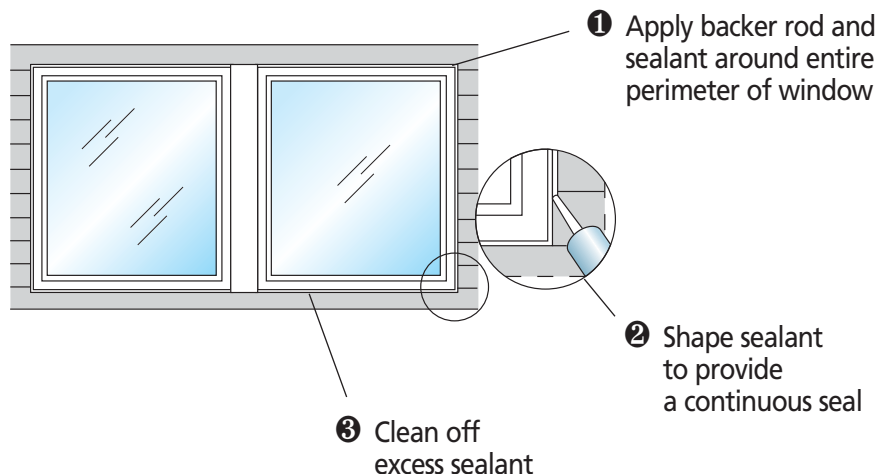

STEP 44

Prepare interior wood surfaces for finishing.

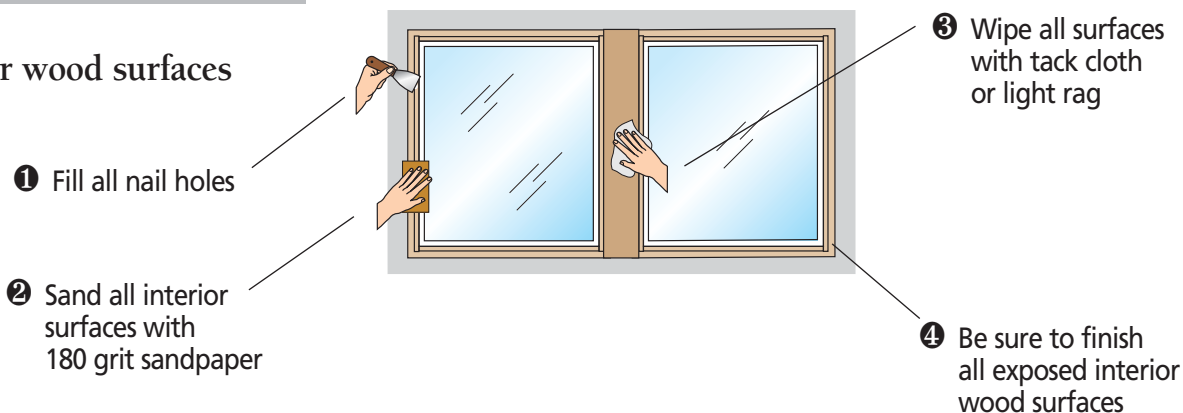

STEP 45

Finish interior wood surfaces.

If painting, apply primer and two coats of paint, overlapping 1/16" onto glass to ensure complete coverage. If applying natural finish, sand and wipe with tack cloth in between coats. Lap 1/16" onto glass to ensure complete coverage. When dry, clean window glass.

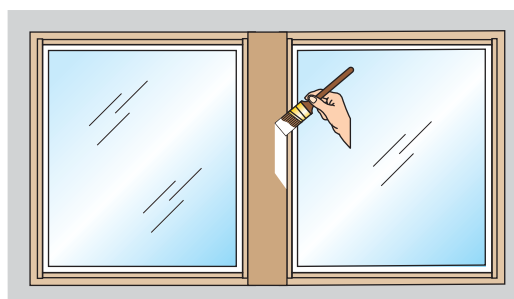

Install hardware.

Depending upon type of window, install hardware as appropriate.

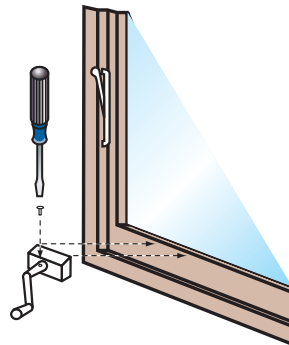

[For casement
and awning windows]

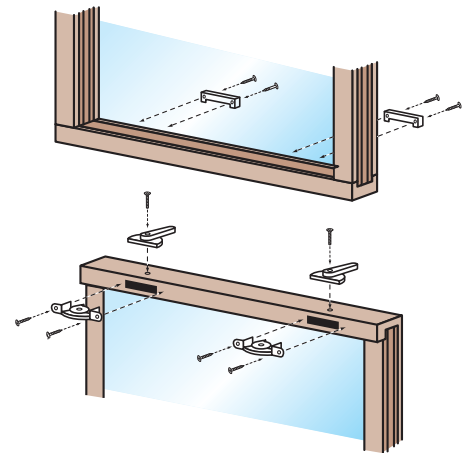

[For double-hung windows]

NOTES

See the Eagle Owner's Manual for care and maintenance information.

Methods and procedures for installation of siding and other cladding materials, trim, moldings and other finish materials around window openings are not specified in these instructions. Such materials should be installed in conformity with the manufacturer's specifications and/or industry standards for such materials. If masonry cladding is used, the soldier course of masonry must be one-half inch away from the bottom of the sill on all windows.

Because all construction must anticipate some water infiltration, it is important that the wall system be designed and constructed to properly manage moisture. Eagle Window & Door is not responsible for claims or damages caused by unanticipated water infiltration, deficiencies in building design, construction and maintenance, failure to install Eagle products in accordance with these instructions, or the use of Eagle products in systems which do not allow for proper management of moisture within the wall system. The determination of the suitability of all building components, including the use of Eagle products, as well as the design and installation of flashing and sealing systems, are the responsibility of you, your architect, or a construction professional. Moisture problems, including unacceptable water infiltration, have been associated with barrier systems such as EIFS (also known as synthetic stucco). Eagle products should not be used in barrier EIFS systems unless Eagle's current, recommended installation procedures for installation of windows and doors into EIFS are used. Any other use of Eagle products with barrier EIFS systems will void the warranty.

Eagle makes no warranty, expressed or implied, that the methods and procedures described in these instructions are suitable for any particular purpose or installation. These instructions do not add to or modify the terms, conditions or limitations of Eagle's manufacturer's warranty.

A drip cap is required on all windows and doors. Failure to utilize and incorporate a drip cap could void the Eagle Window & Door warranty. Refer to the Eagle warranty for additional information.

Tube steel must be treated prior to installation according to manufacturer recommendations and local requirements.

These mullions have been tested in Accordance with AAMA 450 "Voluntary Performance Rating Method for Mullioned Fenestration Assemblies."

It is the responsibility of you and your architect or installing contractor to verify that the methods and mullion materials used meet the project requirements.

Note: E-Z Seal is a registered trademark of Fortifiber Corporation.

Important: Perimeter sealant must be Grade NS Class 24 per ASTM C920 and compatible with the window/door product, nail fin and the finished exterior of the building. Use of improper sealant could result in sealant failure, resulting in air and water infiltration.

